

TREX450 SERIES PERFORMANCE TAIL UPGRADE V2
AT450/450P-PTU-V2 (AL 6061-T6)

ITEM NO.	DESCRIPTION	QTY.
1	TREX 450 SERIES TAIL CONTROL LINK UPGRADE V2	2
2	SAE 660 BRONZE BUSHING 2 x 3 x 2.5MM	2
3	FLANGED RADIAL BALL BEARING MF52ZZ	4
4	M2 x 0.4 x 8MM SOCKET HEAD CAP SCREW ALLOY STEEL	2

NOTE: THE PERFORMANCE TAIL UPGRADE IS A DIRECT RETROFIT FOR THE STOCK ALIGN TAIL CONTROL ASSEMBLY.

WHEN INSTALLING THE FLANGED BALL BEARINGS (3) TO THE TREX 450 SERIES TAIL CONTROL LINK UPGRADE V2 (1), IT IS RECOMMENDED TO APPLY LOCTITE 242 OR SIMILAR TO THE OUTER HOUSING OF THE BALL BEARING. THIS WILL PREVENT THE BEARING FROM SPINNING IN THE HOUSING AND PROVIDE A SOLID, SLOP-FREE TAIL CONTROL ASSEMBLY.

IT IS ALSO RECOMMENDED TO APPLY GREASE BETWEEN THE BRONZE SLEEVE BUSHING (2) AND THE BORE OF THE TREX 450 SERIES TAIL CONTROL LINK UPGRADE V2 (1) TO PROVIDE SMOOTH, BIND-FREE OPERATION.

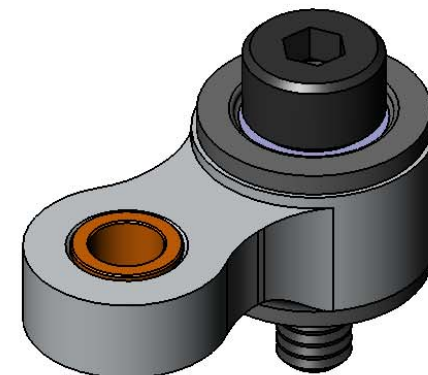
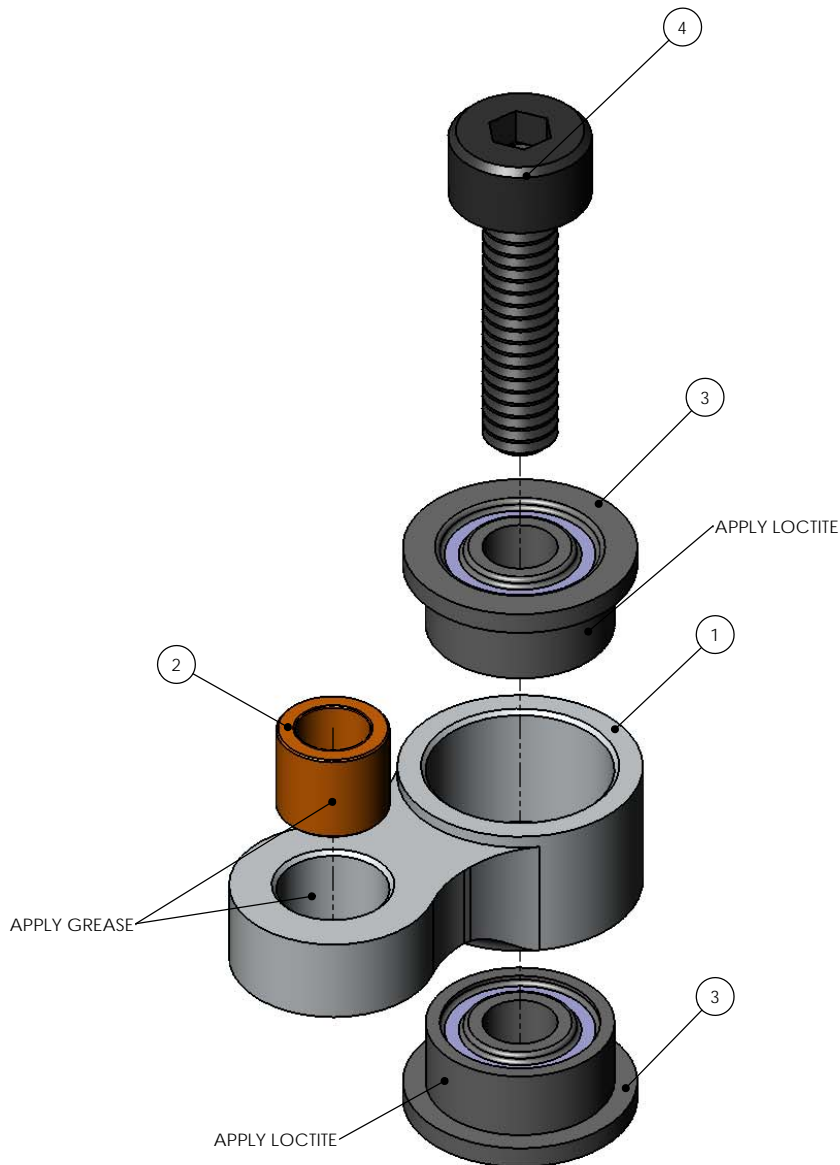

www.KDEDirect.com

www.KDEDirect.com
 AT450/450P-PTU-V2