

**TREX450 SERIES PERFORMANCE TAIL UPGRADE
AT450/450P-PTU (AL 6061-T6)**

ITEM NO.	DESCRIPTION	QTY.
1	TREX 450 SERIES TAIL CONTROL LINK UPGRADE	2
2	BRONZE SLEEVE BUSHING (PROVIDED IN ORIGINAL KIT)	2
3	FLANGED RADIAL BALL BEARING MF52ZZ	2
4	M2 x 0.4 x 6MM SOCKET HEAD CAP SCREW ALLOY STEEL	2

NOTE: THE PERFORMANCE TAIL UPGRADE IS A DIRECT RETROFIT FOR THE STOCK ALIGN TAIL CONTROL ASSEMBLY.

WHEN INSTALLING THE FLANGED BALL BEARING (3) TO THE TREX 450 SERIES TAIL CONTROL LINK UPGRADE (1), IT IS MANDATORY TO APPLY BEARING RETAINER (R48 PROVIDED IN ORIGINAL KIT OR GREEN LOCTITE) TO THE OUTER HOUSING OF THE BALL BEARING. THIS WILL LOCK THE BEARING IN PLACE AND GUARANTEE A SOLID, SLOP-FREE FIT DURING FLIGHT. ALLOW THE LOCTITE TO CURE FOR AT LEAST 1 HOUR BEFORE FLIGHT.

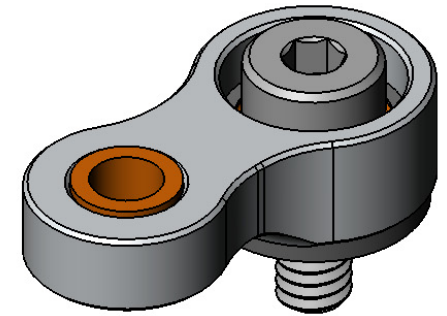
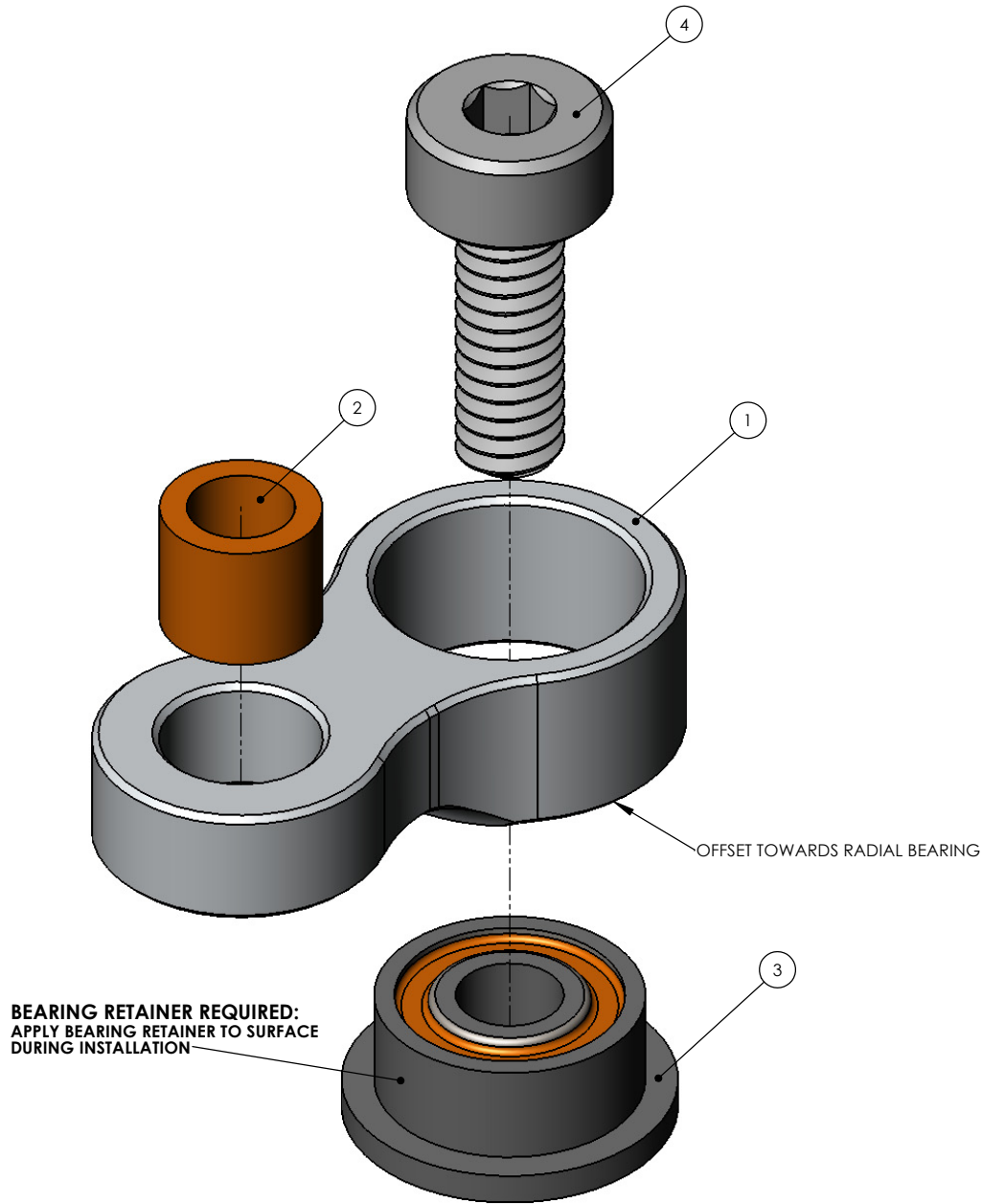

www.KDEDirect.com

www.KDEDirect.com
AT450/450P-PTU