

**TREX450SPORT V2 BOTTOM PLATE UPGRADE**  
**AT450S-BPU (AL 6061-T6)**

ITEM NO.	DESCRIPTION	QTY.
1	M2 x 0.4 x 6MM SOCKET HEAD CAP SCREW CLASS 12.9 BP	4
2	M2 x 0.4 x 10MM SOCKET HEAD CAP SCREW CLASS 12.9 BP	4
3	M2 x 0.4 NYLON INSERT HEX LOCKNUT ALLOY STEEL	4
4	ALIGN TREX M2 x 0.4 x 8MM BUTTON HEAD SOCKET HEAD COLLAR SCREW (INCLUDED IN ORIGINAL KIT)	2

**NOTE:** DUE TO TOLERANCE CONTROL OF THE STOCK FRAMES, LIGHT SANDING OF THE FRAME OR DRILLING OF THE FRAME HOLE LOCATIONS MAY BE NECESSARY TO PROVIDE ACCURATE ALIGNMENT.

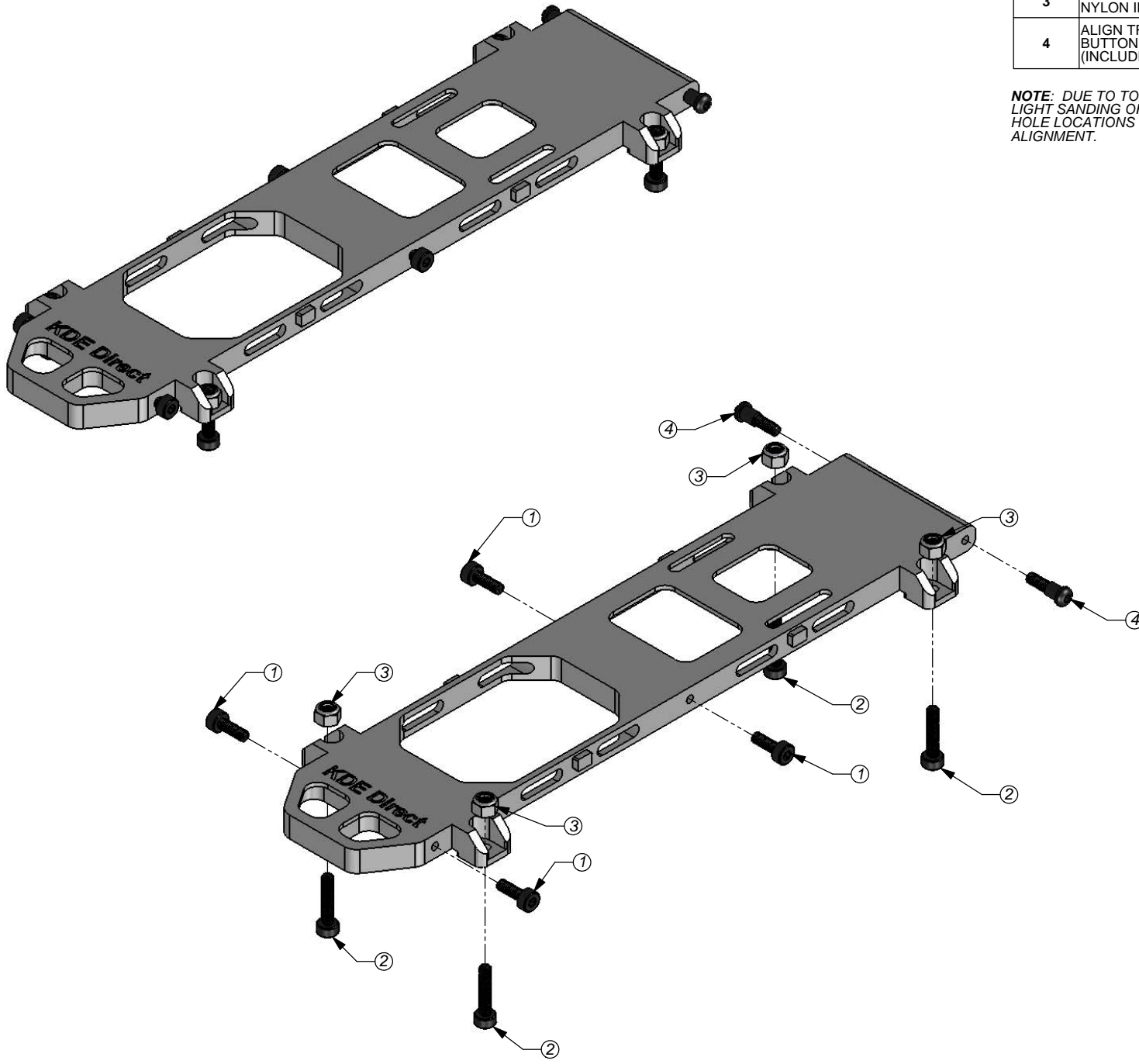

www.KDEDirect.com

www.KDEDirect.com  
 AT450S-BPU