

**TREX500 BOTTOM BRACKET UPGRADE  
AT500-BBU (AL 6061-T6)**

ITEM NO.	DESCRIPTION	QTY.
1	M2.5 x 0.45 x 10MM SOCKET HEAD CAP SCREW ALLOY STEEL	6
2	M2.5 x 0.45 x 12MM SOCKET HEAD CAP SCREW ALLOY STEEL	2
3	M2 x 0.4 x 10MM SOCKET HEAD CAP SCREW ALLOY STEEL	4
4	ALIGN M2.5 SPECIALTY WASHER (PROVIDED IN ORIGINAL KIT)	6
5	ALIGN M2.5 FLAT WASHER (PROVIDED IN ORIGINAL KIT)	2
6	ALIGN M2 FLAT WASHER (PROVIDED IN ORIGINAL KIT)	4

**NOTE:** DUE TO TOLERANCE CONTROL OF THE STOCK FRAMES, LIGHT SANDING OF THE FRAME OR DRILLING OF THE FRAME HOLE LOCATIONS MAY BE NECESSARY TO PROVIDE ACCURATE ALIGNMENT.

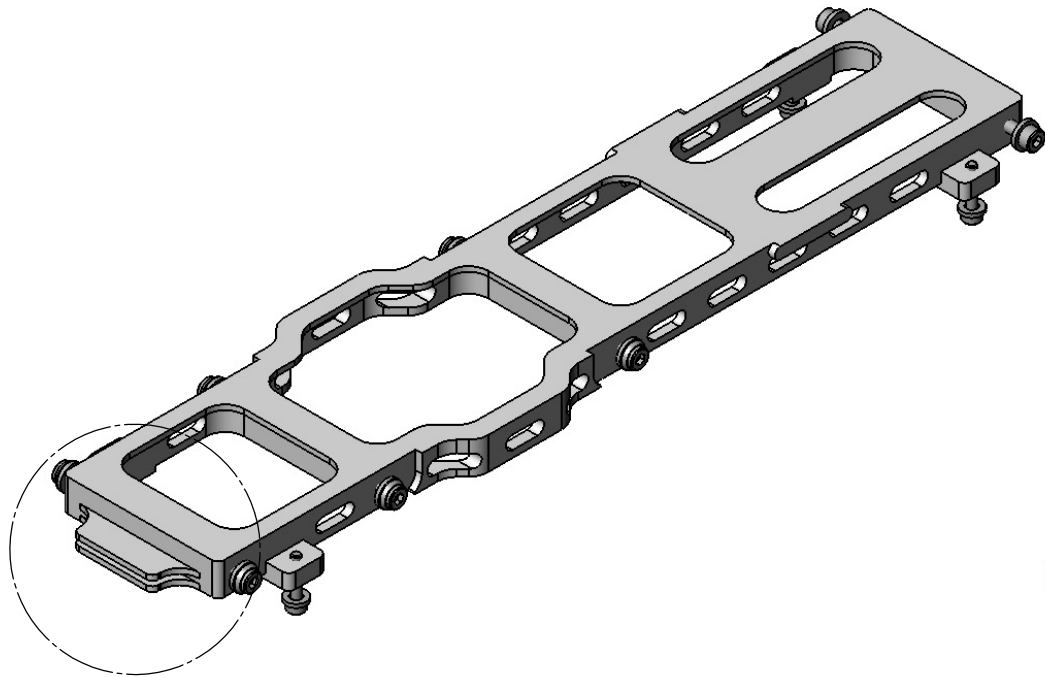

**NOTE:** DUE TO VARYING THICKNESSES OF STOCK AND AFTERMARKET CANOPIES, THE INTEGRATED CANOPY CLIP HAS BEEN DESIGNED TO THE LOWER THICKNESS RANGE OF FIBERGLASS CANOPIES TO ENSURE A TIGHT HOLD DURING FLIGHT AND HARD 3D MANEUVERS. LIGHT SANDING AND/OR DREMELING OF THE CANOPY MATERIAL MAY BE REQUIRED TO ALLOW CERTAIN CANOPIES TO FIT PROPERLY INTO THE CLIP.

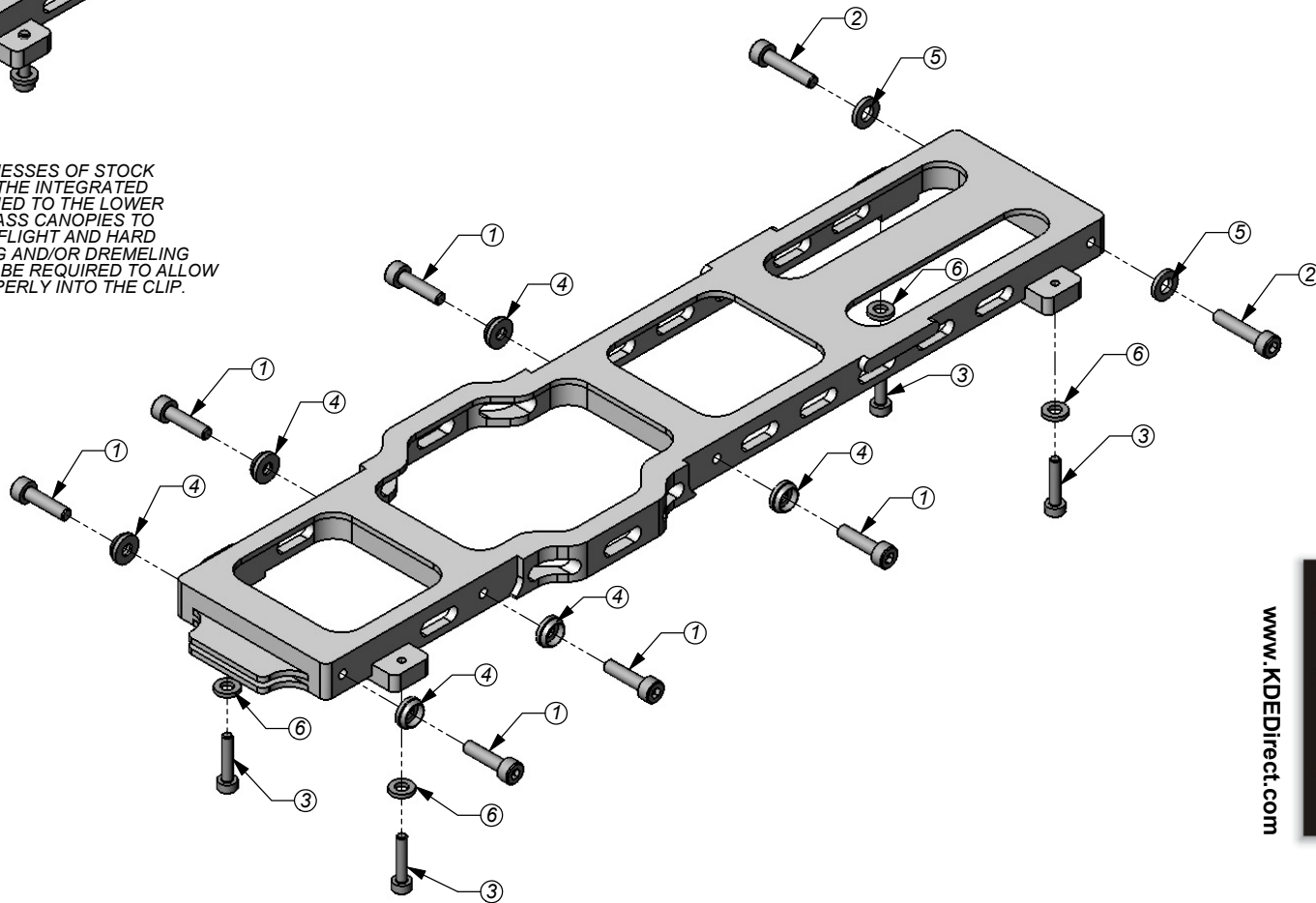

www.KDEDirect.com  
AT500-BBU