

TREX500 SERIES PERFORMANCE TAIL UPGRADE V2
AT500-PTU-V2 (AL 6061-T6)

ITEM NO.	DESCRIPTION	QTY.
1	TREX 500 SERIES TAIL CONTROL LINK UPGRADE V2	2
2	BRONZE SLEEVE BUSHING (PROVIDED IN ORIGINAL KIT)	2
3	FLANGED RADIAL BALL BEARING MF52ZZ	4
4	M2 x 0.4 x 8MM SOCKET HEAD CAP SCREW ALLOY STEEL	2

NOTE: THE PERFORMANCE TAIL UPGRADE IS A DIRECT RETROFIT FOR THE STOCK ALIGN TAIL CONTROL ASSEMBLY.

WHEN INSTALLING THE FLANGED BALL BEARINGS (3) TO THE TREX 500 SERIES TAIL CONTROL LINK UPGRADE V2 (1), IT IS RECOMMENDED TO APPLY LOCTITE 242 OR SIMILAR TO THE OUTER HOUSING OF THE BALL BEARING. THIS WILL PREVENT THE BEARING FROM SPINNING IN THE HOUSING AND PROVIDE A SOLID, SLOP-FREE TAIL CONTROL ASSEMBLY.

IT IS ALSO RECOMMENDED TO APPLY GREASE BETWEEN THE BRONZE SLEEVE BUSHING (2) AND THE BORE OF THE TREX 500 SERIES TAIL CONTROL LINK UPGRADE V2 (1) TO PROVIDE SMOOTH, BIND-FREE OPERATION.

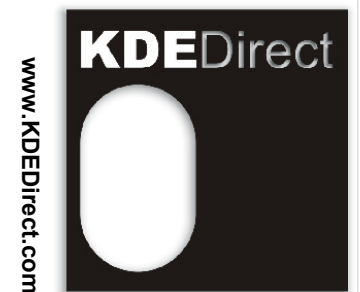
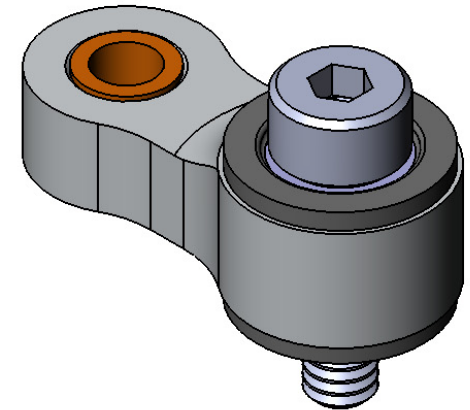
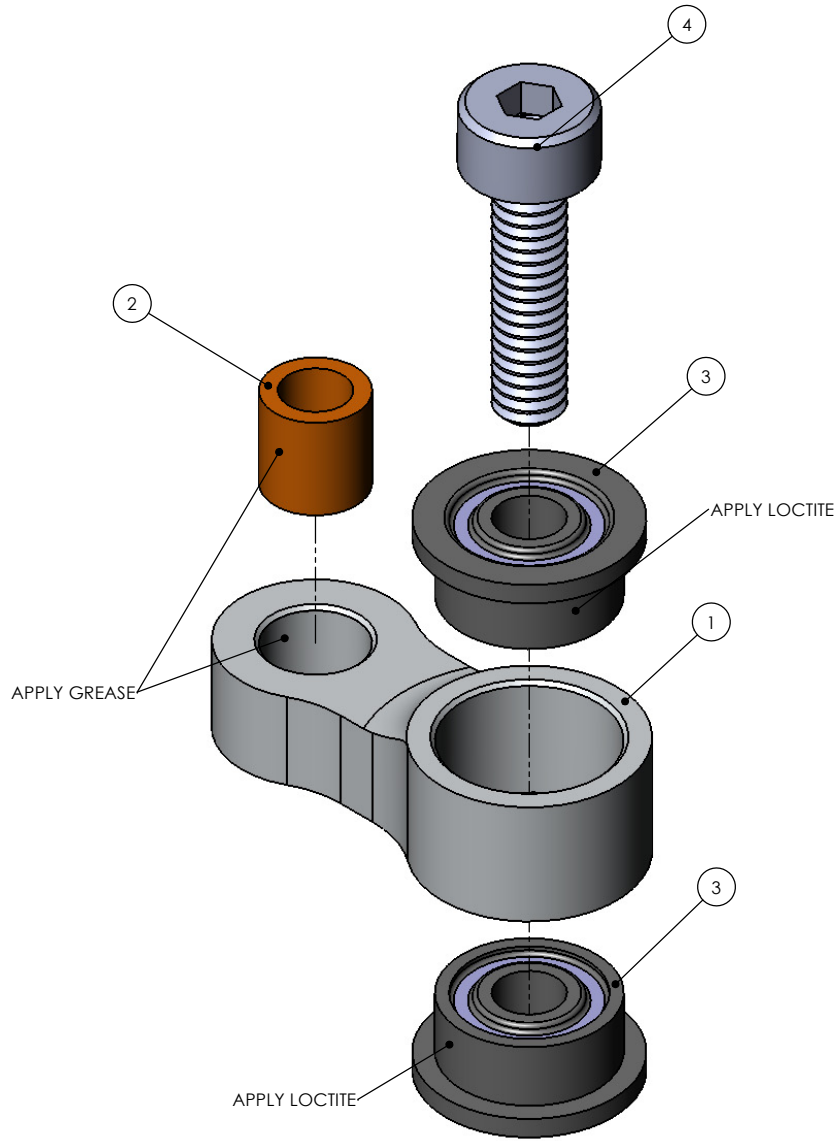

www.KDEDirect.com
AT500-PTU-V2