

TREX 500PRO THRUSTED METAL BEARING BLOCKS

AT500P-MBB (AL 6061-T6)

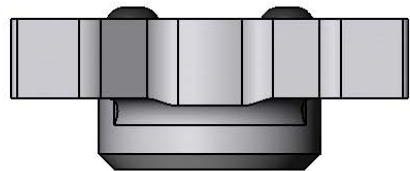

UPPER METAL BEARING BLOCK

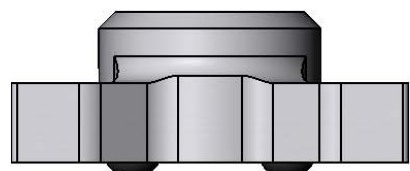
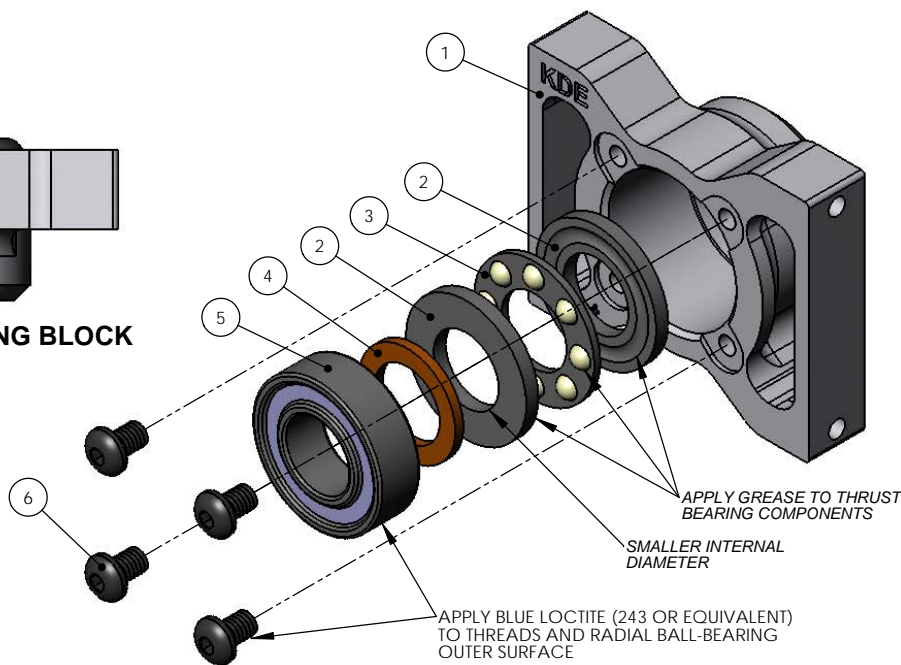

LOWER METAL BEARING BLOCK

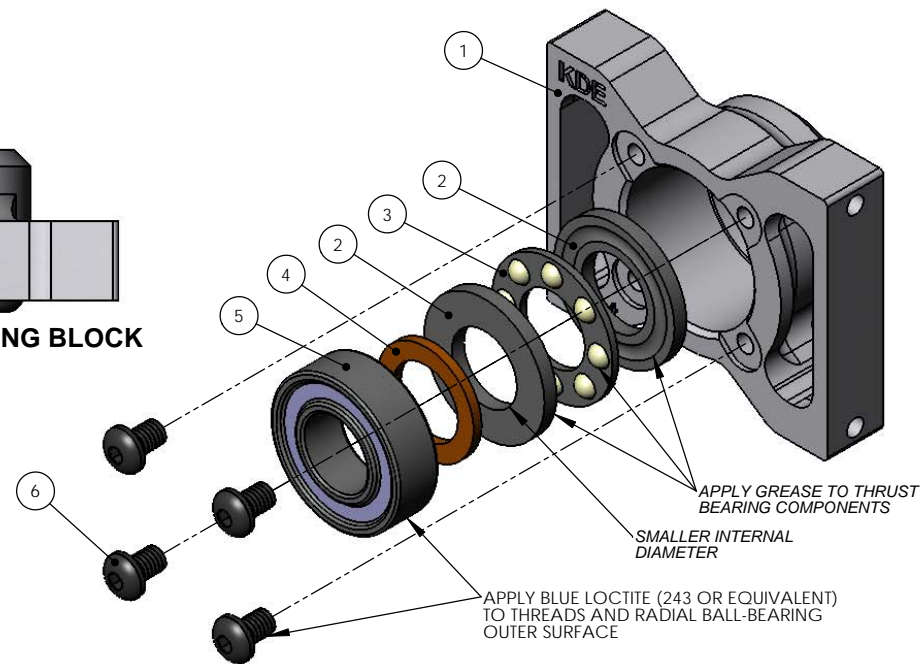

ITEM NO.	DESCRIPTION	QTY.
1	KDE DIRECT TREX 500 PRO SERIES THRUSTED METAL BEARING BLOCK	2
2	THRUST BEARING RACE 15MM	4
3	THRUST BEARING BALL CONTAINER 15MM	2
4	THRUST BEARING SPACER 8x12x1MM	2
5	RADIAL BALL BEARING 688ZZ	2
6	M2.5 x 0.45 x 4MM BUTTON HEAD SOCKET HEAD CAP SCREWS	8

NOTE: THE THRUSTED METAL BEARING BLOCKS HAVE BEEN CNC MACHINED TO PRECISE TOLERANCES FOR THE BEARINGS. WHEN INSERTING THE RADIAL BEARINGS, ALIGN THE BEARING TO THE BORE ACCURATELY AND THEN PRESS IN BY HAND. BE CAREFUL TO ONLY APPLY PRESSURE TO THE OUTER-EDGE OF THE BEARING TO PREVENT DAMAGE TO THE INTERNAL COMPONENTS. DO NOT PUSH ON THE INNER, ROTATING RACE OF THE BEARING DURING INSTALLATION.

THE RADIAL BEARING IS DESIGNED TO FLOAT VERTICALLY IN THE BEARING BLOCKS, WHICH ALLOWS ALL AXIAL FORCES TO BE TRANSFERRED TO THE THRUST BEARINGS.

APPLY A SMALL AMOUNT OF MEDIUM-STRENGTH LOCTITE (BLUE 243 OR EQUIVALENT) TO THE OUTER SURFACE OF THE RADIAL BEARING AND THE BUTTON HEAD SOCKET HEAD CAP SCREWS TO HOLD IT IN PLACE DURING INSTALLATION. THIS WILL PREVENT THE BEARINGS FROM FALLING OUT DURING INSTALLATION/REMOVAL OF THE MAIN DRIVE GEAR ASSEMBLY, WHILE STILL ALLOWING THE RADIAL BEARING TO FLOAT AXIALLY UNDER HIGH LOADS OF FLIGHT. **DO NOT** USE BEARING RETAINER OR HIGH-STRENGTH LOCTITE FOR THE INSTALL.

APPLY ANY BEARING-QUALITY, SYNTHETIC OR SILICON-BASED GREASE TO THE THRUST BEARING COMPONENTS BEFORE INSTALLATION.

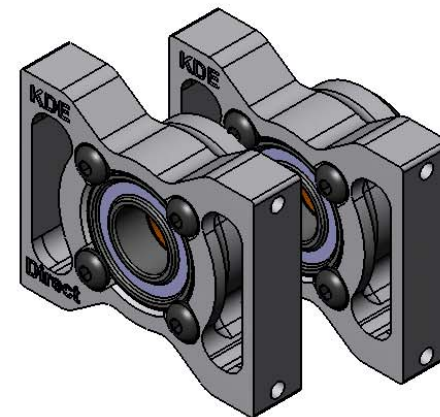

www.KDEDirect.com

www.KDEDirect.com
AT500P-MBB