

TREX550/600/700 SERIES PERFORMANCE TAIL UPGRADE V2

AT550/600/700-PTU-V2 (AL 6061-T6)

ASSEMBLY ORDER

1. M3 x 0.5 x 12MM BUTTON HEAD SOCKET HEAD CAP SCREW
2. M3 FLAT WASHER WIDE
3. RADIAL BALL BEARING 623ZZ
4. M3 FLAT WASHER NARROW
5. THRUST BEARING F5-10M
6. TAIL ROTOR HOLDER
7. RADIAL BALL BEARING MR105ZZ

GROUP A

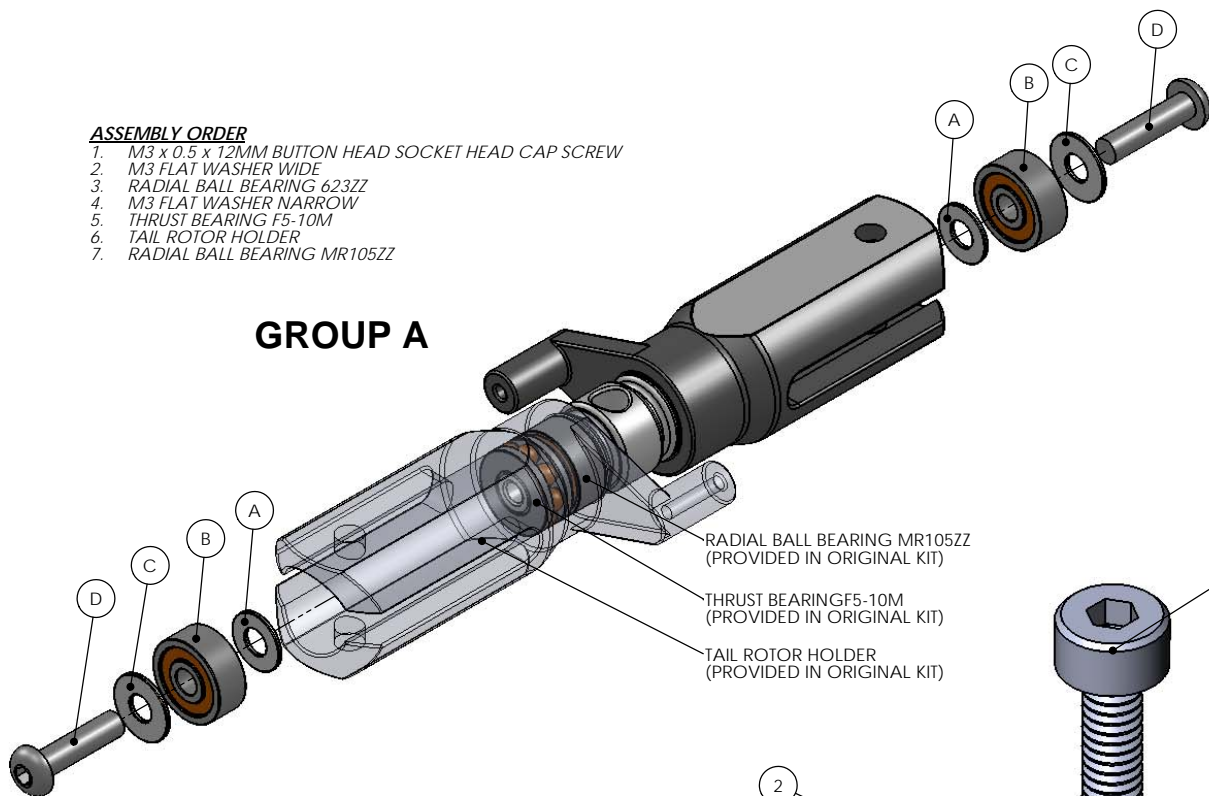

RADIAL BALL BEARING MR105ZZ
(PROVIDED IN ORIGINAL KIT)

THRUST BEARING F5-10M
(PROVIDED IN ORIGINAL KIT)

TAIL ROTOR HOLDER
(PROVIDED IN ORIGINAL KIT)

GROUP B

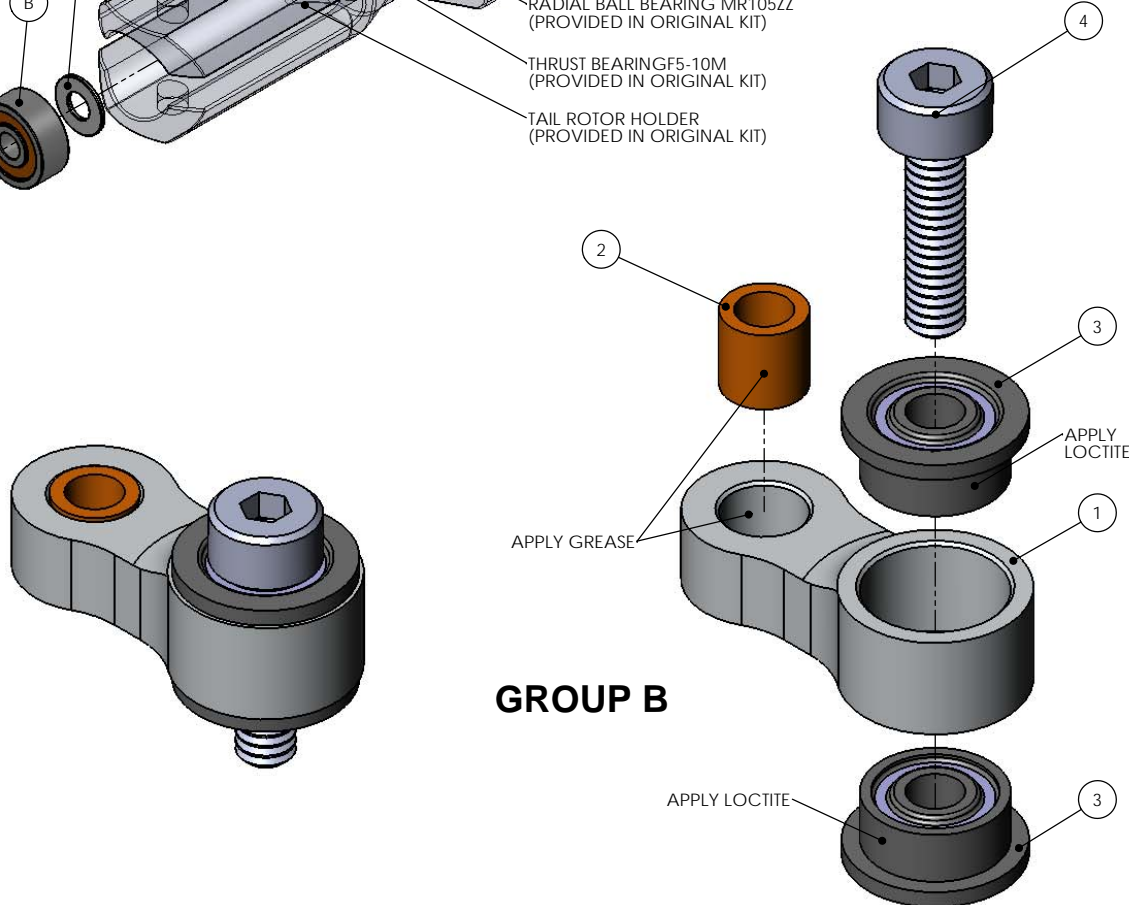

APPLY GREASE

APPLY LOCTITE

APPLY LOCTITE

GROUP A

ITEM NO.	DESCRIPTION	QTY.
A	M3 FLAT WASHER ZP STEEL	2
B	623ZZ RADIAL BALL BEARING 3 x 8 x 4MM	2
C	M3 FLAT WASHER WIDE (PROVIDED IN ORIGINAL KIT)	2
D	M3 x 0.5 x 12MM BUTTON HEAD SOCKET HEAD CAP SCREW ALLOY STEEL	2

NOTE: THE PERFORMANCE TAIL UPGRADE IS A DIRECT RETROFIT FOR THE STOCK ALIGN TAIL ROTOR HOLDER ASSEMBLY (PLASTIC OR METAL VERSIONS). THE UPGRADE CONVERTS THE TAIL ASSEMBLY TO A DUAL RADIAL BALL BEARING, FULLY-SUPPORTED THRUST BEARING SETUP IDEAL FOR ALL FLIGHT CONDITIONS.

TO INSTALL THE UPGRADE:

1. REMOVE THE STOCK M3 x 0.5 x 8MM SOCKET HEAD CAP SCREW FROM BOTH SIDE OF THE ALIGN TAIL ROTOR HOLDER. KEEP THE ORIGINAL M3 FLAT WASHERS WIDE (C), WHICH WILL BE REUSED AT STEP #3.
2. DO NOT REMOVE THE ORIGINAL RADIAL BALL BEARING AND THRUST BEARING (SEE FIGURE FOR REFERENCE).
3. INSERT THE M3 FLAT WASHER NARROW (A), FOLLOWED BY THE RADIAL BALL BEARING 623ZZ (B), AND THEN THE M3 FLAT WASHER WIDE (C) ORIGINALLY INCLUDED WITH THE ASSEMBLY.
4. TIGHTEN DOWN THE ENTIRE ASSEMBLY USING THE TWO M3 x 0.5 x 12MM BUTTON HEAD SOCKET HEAD CAP SCREWS.

GROUP B

ITEM NO.	DESCRIPTION	QTY.
1	TREX 550/600/700 SERIES TAIL CONTROL LINK UPGRADE V2	2
2	BRONZE SLEEVE BUSHING (PROVIDED IN ORIGINAL KIT)	2
3	MF52ZZ FLANGED RADIAL BALL BEARING 2 x 5 x 2.5MM	4
4	M2 x 0.4 x 8MM SOCKET HEAD CAP SCREW ALLOY STEEL	2

NOTE: THE PERFORMANCE TAIL UPGRADE IS A DIRECT RETROFIT FOR THE STOCK ALIGN TAIL CONTROL ASSEMBLY.

WHEN INSTALLING THE FLANGED BALL BEARINGS (3) TO THE TREX 550/600/700 SERIES TAIL CONTROL LINK UPGRADE V2 (1), IT IS RECOMMENDED TO APPLY LOCTITE 242 OR SIMILAR TO THE OUTER HOUSING OF THE BALL BEARING. THIS WILL PREVENT THE BEARING FROM SPINNING IN THE HOUSING AND PROVIDE A SOLID, SLOP-FREE TAIL CONTROL ASSEMBLY.

IT IS ALSO RECOMMENDED TO APPLY GREASE BETWEEN THE BRONZE SLEEVE BUSHING (2) AND THE BORE OF THE TREX 550/600/700 SERIES TAIL CONTROL LINK UPGRADE V2 (1) TO PROVIDE SMOOTH, BIND-FREE OPERATION.

www.KDEDirect.com



www.KDEDirect.com
AT550/600/700-PTU-V2