

# TREX550/600 MAIN GEAR CASE UPGRADE AT550/600-MGC (AL 6061-T6)

## STEP 1: ONE-WAY CLUTCH BEARING INSTALLATION

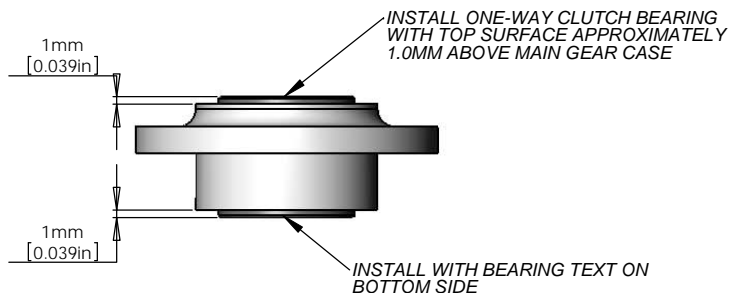
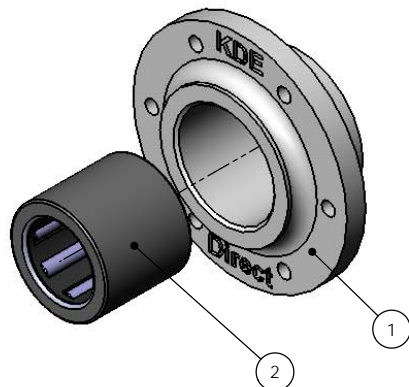

ITEM NO.	DESCRIPTION	QTY.
1	TREX 550/600 SERIES T700 MAIN GEAR CASE	1
2	DRAWN CUP ROLLER CLUTCH, HF1216 (PROVIDED IN ORIGINAL KIT)	1
3	KDE DIRCT TREX 700 SERIES NYLATRON MAIN DRIVE GEAR (PURCHASE SEPARATELY)	1
4	M3 x 0.45 x 6MM BUTTON HEAD SOCKET HEAD CAP SCREW	6

**NOTE:** THE MAIN GEAR CASE HAS BEEN DESIGNED FOR AN OPTIMAL PRESS-FIT BETWEEN THE INNER BORE AND THE ONE-WAY CLUTCH BEARING TO AID IN EASE OF ASSEMBLY.

TO PREVENT SLIPPAGE DURING FLIGHT, APPLY RED OR GREEN LOCTITE (262, 271, 290, OR 640) TO THE INNER BORE OF THE MAIN GEAR CASE BEFORE ASSEMBLY (DO NOT ALLOW ANY LOCTITE TO ENTER THE BEARING CLUTCH). ONCE PROPERLY INSTALLED (SEE DIAGRAM FOR LOCATIONAL INFORMATION), WIPE AWAY ANY EXCESS LOCTITE AND ALLOW THE ASSEMBLY TO CURE FOR 1 HOUR BEFORE FLIGHT.

**OPTIONAL INSTALL:** THE MAIN GEAR CASE CAN BE USED WITH THE KDE DIRECT TREX 700 SERIES MAIN DRIVE GEARS FOR UNPRECEDENTED STRENGTH CAPABILITY FOR HIGH-POWER, HIGH-VOLTAGE TREX 550/600 SETUPS (APPROPRIATE MOD1.0 PINION SOLD SEPARATELY). TIGHT TOLERANCES BETWEEN THE MAIN DRIVE GEAR AND MAIN GEAR CASE ARE USED TO MAINTAIN PERFECT CONCENTRICITY WITH THE GEAR.

WHEN INSTALLING THE MAIN DRIVE GEAR, USE THE SUPPLIED SCREWS (OR A LONGER M3 SCREW) TO PULL THE MAIN GEAR CASE INTO THE MAIN DRIVE GEAR AND ESTABLISH A SOLID SETUP. ONCE THE MAIN GEAR CASE IS FLUSH INSIDE THE MAIN DRIVE GEAR, FINISH THE INSTALLATION USING THE SUPPLIED M3 BUTTON HEAD SOCKET HEAD CAP SCREWS AND LOCTITE 242 (BLUE OR EQUIVALENT).

## OPTIONAL

## STEP 2: KDE DIRECT TREX 700 SERIES MAIN DRIVE GEAR INSTALLATION (MOD0.7 OR MOD1.0)

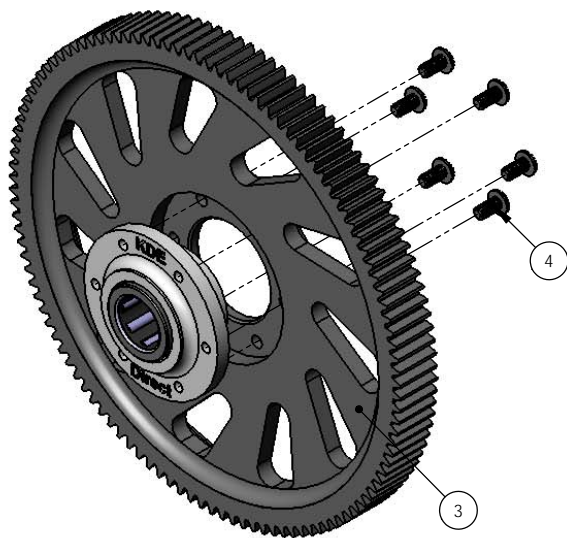

www.KDEDirect.com



www.KDEDirect.com  
AT550/600-MGC