

# TREX550/600 UNIVERSAL MOTOR MOUNT AT550/600-UMM (AL 6061-T6)

**NOTE: FOR PROPER INSTALLATION OF THE SIDE RAILS, A MAXIMUM SCREW LENGTH OF 9MM IS ALLOWED FOR THE MOTOR MOUNT. APPROPRIATE M3 x 0.5 x 8MM FASTENERS HAVE BEEN PROVIDED FOR CORRECT INSTALLATION.**

ITEM NO.	DESCRIPTION	QTY.
1	T550/600 SERIES UNIVERSAL MOTOR MOUNT PLATE	1
2	T550/600 SERIES UNIVERSAL MOTOR MOUNT RAIL	2
3	M3 x 0.5 x 8MM SOCKET HEAD CAP SCREW ALLOY STEEL	4
4	KDE DIRECT 1907H/1Y-N42 HP BRUSHLESS MOTOR, 1220KV (SHOWN FOR REFERENCE, SOLD SEPARATELY)	1
5	REVC O HARDENED STEEL PINION GEAR, 6MM (SHOWN FOR REFERENCE, SOLD SEPARATELY)	1
6	T700 SERIES MAIN DRIVE GEAR (SHOWN FOR REFERENCE, SOLD SEPARATELY)	1

**NOTE: THE UNIVERSAL MOTOR MOUNT COMPONENTS HAVE BEEN CNC MACHINED TO PRECISE TOLERANCES FOR ACCURATE ALIGNMENT AND PROPER OPERATION. DUE TO THE TIGHT TOLERANCES (TO PREVENT SLOP WITHIN THE MOUNT INTERFACE), SLIGHT BINDING MAY OCCUR DURING THE FULL RANGE OF ADJUSTMENT. IF BINDING OCCURS, A PIECE OF HIGH-GRIT SANDPAPER (400 GRIT OR HIGHER) CAN BE USED TO SMOOTH THE MOTOR MOUNT RAILS. THIS WILL REMOVE EXCESS CHROMATE COATING AND PROVIDE A SMOOTH, SLOP-FREE MOUNT FOR THE UPGRADE.**

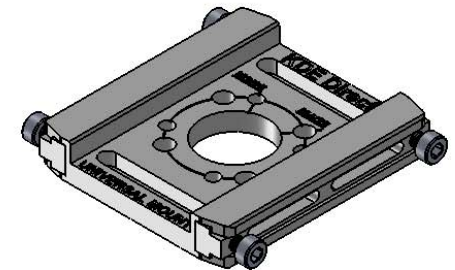
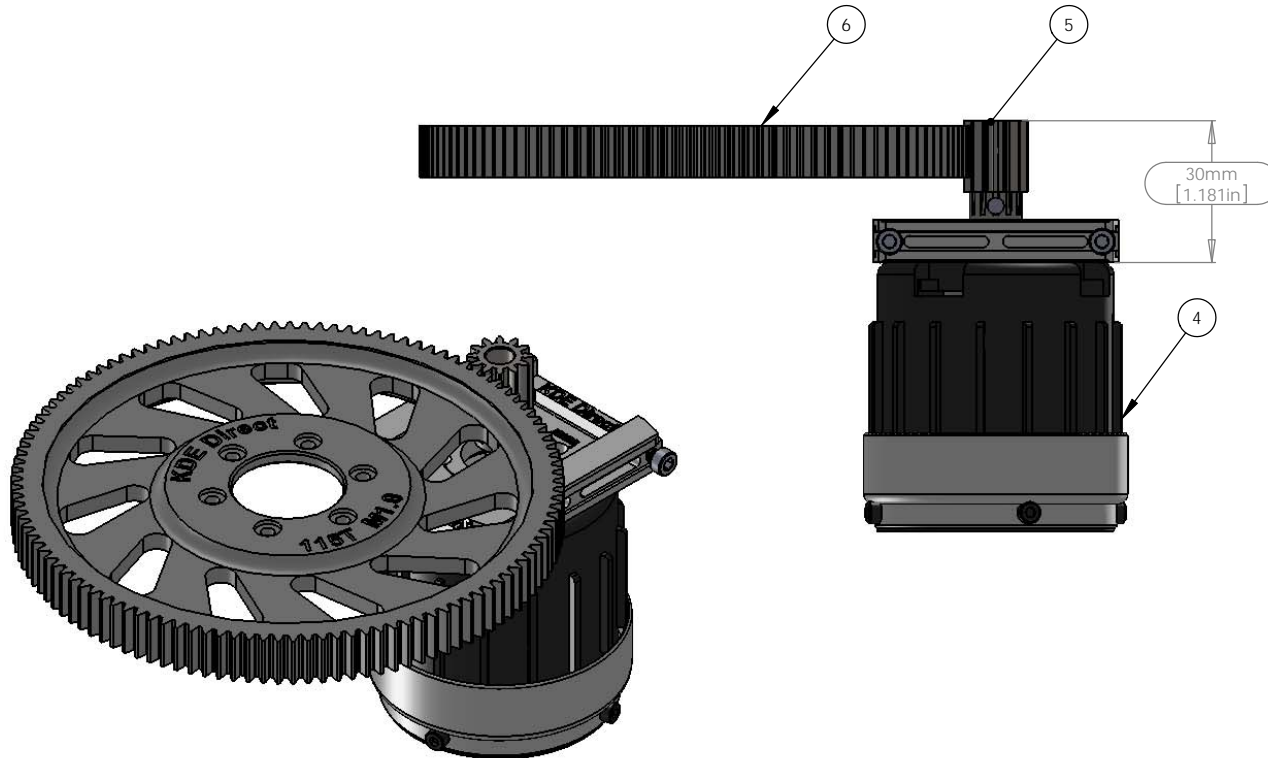
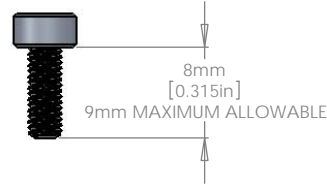
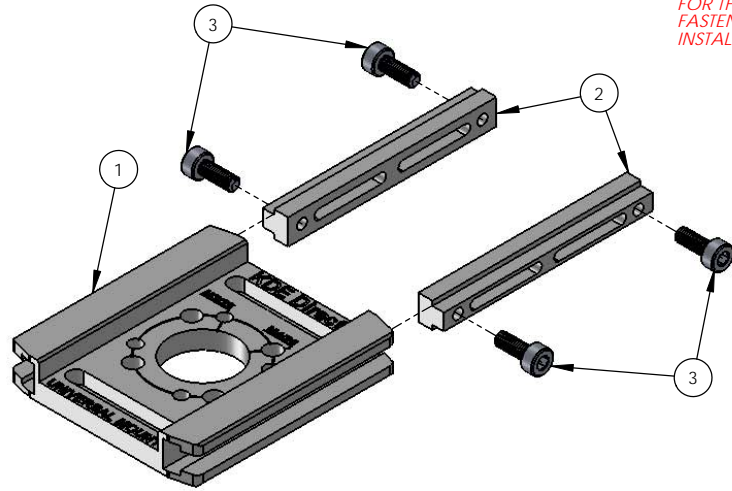

www.KDEDirect.com  
AT550/600-UMM