

TREX600 AND 700 SERIES PERFORMANCE TAIL UPGRADE AT600/600N/700N-PTU (AL 6061-T6)

ASSEMBLY ORDER

1. M3 x 0.5 x 12MM BUTTON HEAD SOCKET HEAD CAP SCREW
2. M3 FLAT WASHER WIDE
3. RADIAL BALL BEARING 623ZZ
4. M3 FLAT WASHER NARROW
5. THRUST BEARING F5-10M
6. TAIL ROTOR HOLDER
7. RADIAL BALL BEARING MR105ZZ

GROUP A

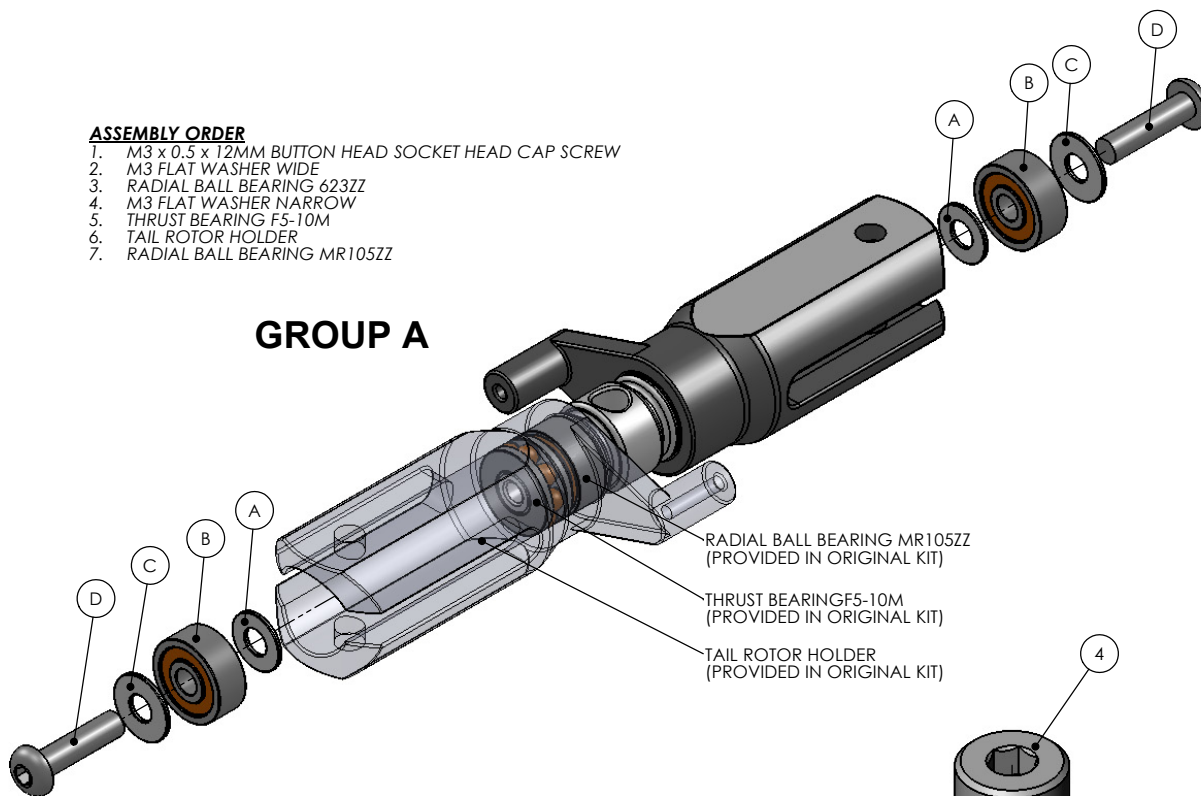

RADIAL BALL BEARING MR105ZZ
(PROVIDED IN ORIGINAL KIT)

THRUST BEARING F5-10M
(PROVIDED IN ORIGINAL KIT)

TAIL ROTOR HOLDER
(PROVIDED IN ORIGINAL KIT)

GROUP B

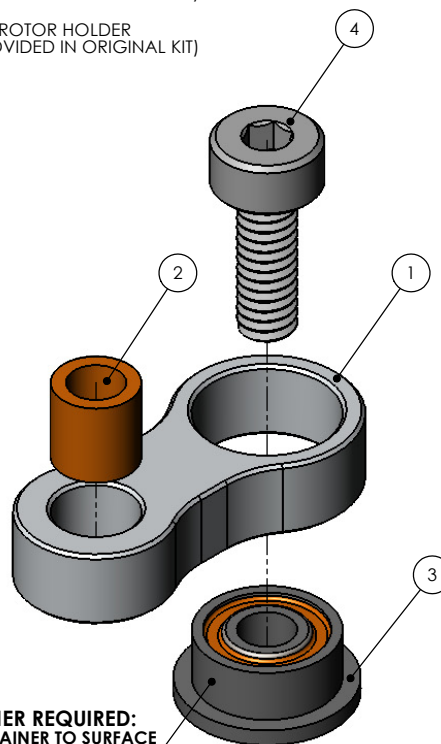

BEARING RETAINER REQUIRED:
APPLY BEARING RETAINER TO SURFACE
DURING INSTALLATION

GROUP A

ITEM NO.	DESCRIPTION	QTY.
A	M3 FLAT WASHER ZP STEEL	2
B	RADIAL BALL BEARING 623ZZ	2
C	M3 FLAT WASHER WIDE (PROVIDED IN ORIGINAL KIT)	2
D	M3 x 0.5 x 12MM BUTTON HEAD SOCKET HEAD CAP SCREW ALLOY STEEL	2

NOTE: THE PERFORMANCE TAIL UPGRADE IS A DIRECT RETROFIT FOR THE STOCK ALIGN TAIL ROTOR HOLDER ASSEMBLY (PLASTIC OR METAL VERSIONS). THE UPGRADE CONVERTS THE TAIL ASSEMBLY TO A DUAL RADIAL BALL BEARING, FULLY-SUPPORTED THRUST BEARING SETUP IDEAL FOR ALL FLIGHT CONDITIONS.

TO INSTALL THE UPGRADE:

1. REMOVE THE STOCK M3 x 0.5 x 8MM SOCKET HEAD CAP SCREW FROM BOTH SIDE OF THE ALIGN TAIL ROTOR HOLDER. KEEP THE ORIGINAL M3 FLAT WASHERS WIDE (C), WHICH WILL BE REUSED AT STEP #3.
2. DO NOT REMOVE THE ORIGINAL RADIAL BALL BEARING AND THRUST BEARING (SEE FIGURE FOR REFERENCE).
3. INSERT THE M3 FLAT WASHER NARROW (A), FOLLOWED BY THE RADIAL BALL BEARING 623ZZ (B), AND THEN THE M3 FLAT WASHER WIDE (C) ORIGINALLY INCLUDED WITH THE ASSEMBLY.
4. TIGHTEN DOWN THE ENTIRE ASSEMBLY USING THE TWO M3 x 0.5 x 12MM BUTTON HEAD SOCKET HEAD CAP SCREWS.

GROUP B

ITEM NO.	DESCRIPTION	QTY.
1	TREX 600/700 SERIES TAIL CONTROL LINK UPGRADE	2
2	BRONZE SLEEVE BUSHING (PROVIDED IN ORIGINAL KIT)	2
3	MF52zz FLANGED RADIAL BALL BEARING 2x5x2.5 mm	2
4	M2 x 0.4 x 6MM SOCKET HEAD CAP SCREW ALLOY STEEL	2

NOTE: THE PERFORMANCE TAIL UPGRADE IS A DIRECT RETROFIT FOR THE STOCK ALIGN TAIL CONTROL ASSEMBLY.

WHEN INSTALLING THE FLANGED BALL BEARING (3) TO THE TREX 600/700 SERIES TAIL CONTROL LINK UPGRADE (1), IT IS MANDATORY TO APPLY BEARING RETAINER (R48 PROVIDED IN ORIGINAL KIT OR GREEN LOCTITE) TO THE OUTER HOUSING OF THE BALL BEARING. THIS WILL LOCK THE BEARING IN PLACE AND GUARANTEE A SOLID, SLOP-FREE FIT DURING FLIGHT. ALLOW THE LOCTITE TO CURE FOR AT LEAST 1 HOUR BEFORE FLIGHT.

www.KDEDirect.com



www.KDEDirect.com
AT600/600N/700N-PTU