

TREX600 THRUSTED METAL BEARING BLOCKS
AT600-MBB (AL 6061-T6)

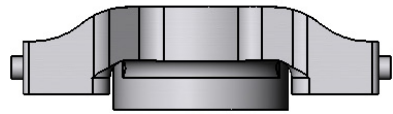

UPPER METAL BEARING BLOCK

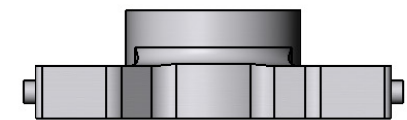
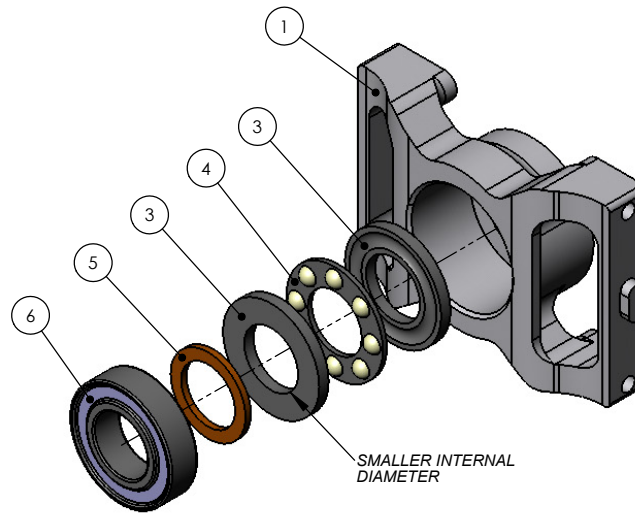

LOWER METAL BEARING BLOCK

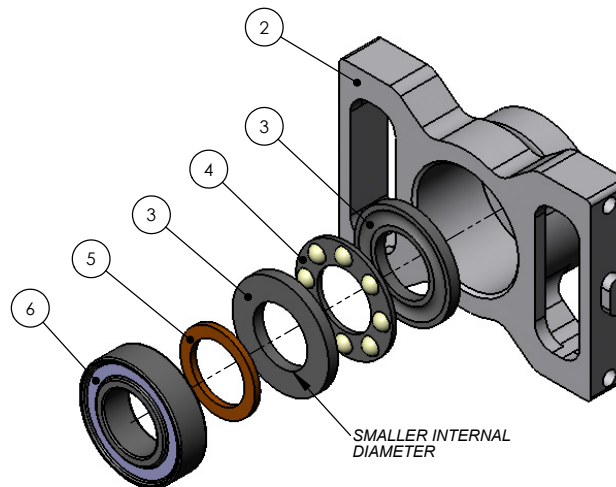

ITEM NO.	DESCRIPTION	QTY.
1	T600 THRUSTED METAL BEARING BLOCK UPPER	1
2	T600 THRUSTED METAL BEARING BLOCK LOWER	1
3	THRUST BEARING RACE 18MM	4
4	THRUST BEARING BALL CONTAINER 18MM	2
5	THRUST BEARING SPACER 10x14x1MM	2
6	RADIAL BALL BEARING 6800ZZ	2

NOTE: THE METAL BEARING BLOCKS HAVE BEEN CNC MACHINED TO PRECISE TOLERANCES FOR THE BEARINGS. WHEN INSERTING THE RADIAL BEARINGS, ALIGN THE BEARING TO THE BORE ACCURATELY AND THEN PRESS IN BY HAND. IF A PRESS-FIT IS REQUIRED, BE CAREFUL TO ONLY APPLY PRESSURE TO THE OUTER-EDGE OF THE BEARING TO PREVENT DAMAGE TO THE INTERNAL COMPONENTS.

DO NOT PUSH ON THE INNER, ROTATING RACE OF THE BEARING DURING INSTALLATION.

THE RADIAL BEARING IS DESIGNED TO FLOAT VERTICALLY IN THE BEARING BLOCKS, WHICH ALLOWS ALL AXIAL FORCES TO BE TRANSFERRED TO THE THRUST BEARINGS. LOCTITE IS NOT REQUIRED FOR PROPER OPERATION AND ANY RADIAL LOAD WILL LOCK THE OUTER RACE OF THE RADIAL BEARING AGAINST THE HOUSING DURING FLIGHT.

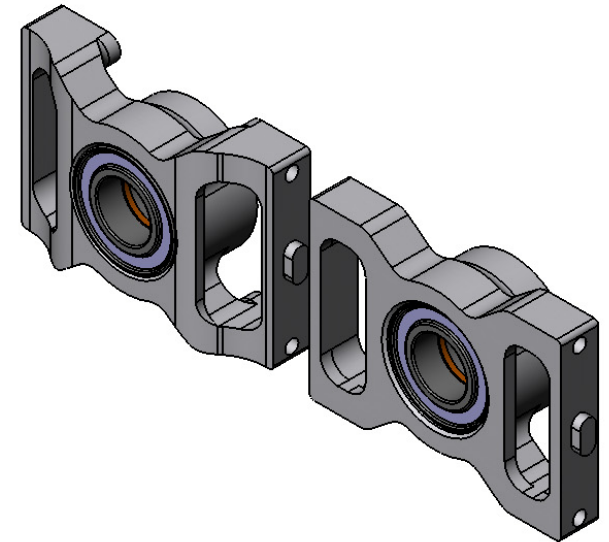

www.KDEDirect.com

www.KDEDirect.com
AT600-MBB