

**TREX600 AL T700N MAIN GEAR CASE UPGRADE**  
**AT600-MGC (AL 6061-T6)**

ITEM NO.	DESCRIPTION	QTY.
1	T600 AL T700N METAL MAIN GEAR CASE UPGRADE	1
2	DRAWN CUP ROLLER CLUTCH (HF1216) (PROVIDED IN ORIGINAL KIT)	1

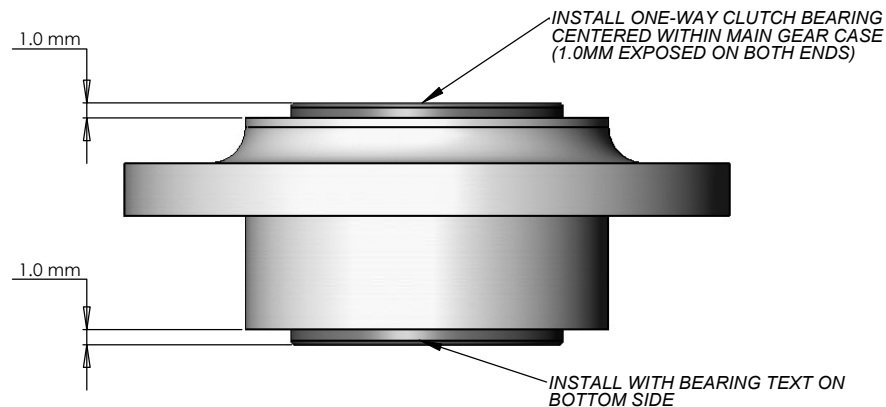

**NOTE:** THE MAIN GEAR CASE HAS BEEN DESIGNED FOR AN OPTIMAL PRESS-FIT BETWEEN THE INNER BORE AND THE ONE-WAY CLUTCH BEARING TO AID IN EASE OF ASSEMBLY.

TO PREVENT SLIPPAGE DURING FLIGHT, APPLY RED OR GREEN LOCTITE (262, 271, 290, OR 640) TO THE INNER BORE OF THE MAIN GEAR CASE BEFORE ASSEMBLY (DO NOT ALLOW ANY LOCTITE TO ENTER THE BEARING CLUTCH). ONCE PROPERLY INSTALLED (1MM EXPOSED ON BOTH ENDS AS SHOWN IN DIAGRAM), WIPE AWAY ANY EXCESS LOCTITE AND ALLOW THE ASSEMBLY TO CURE FOR 1 HOUR BEFORE FLIGHT.



www.KDEDirect.com  
**AT600-MGC**