

TREX600N THRUSTED METAL BEARING BLOCKS AT600N-MBB (AL 6061-T6)

ITEM NO.	DESCRIPTION	QTY.
1	T600N THRUSTED METAL BEARING BLOCK UPPER	1
2	T600N THRUSTED METAL BEARING BLOCK LOWER	1
3	THRUST BEARING RACE 18MM	4
4	THRUST BEARING BALL CONTAINER 18MM	2
5	THRUST BEARING SPACER 10x14x1MM	2
6	RADIAL BALL BEARING 6800ZZ	2

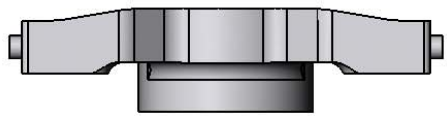

UPPER METAL BEARING BLOCK

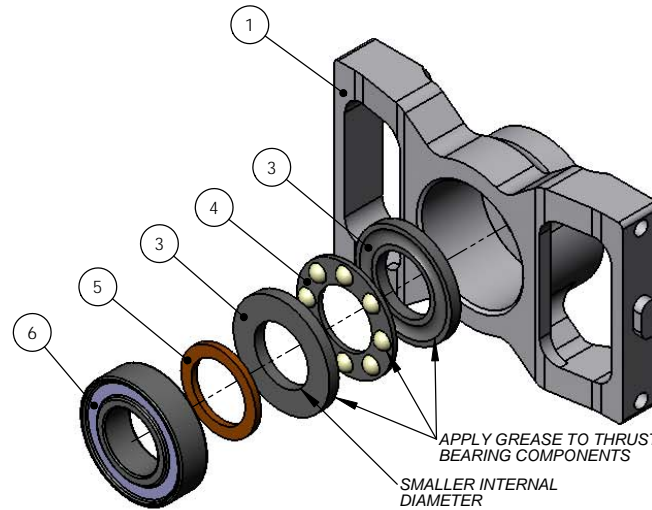

NOTE: THE THRUSTED METAL BEARING BLOCKS HAVE BEEN CNC MACHINED TO PRECISE TOLERANCES FOR THE BEARINGS. WHEN INSERTING THE RADIAL BEARINGS, ALIGN THE BEARING TO THE BORE ACCURATELY AND THEN PRESS IN BY HAND. BE CAREFUL TO ONLY APPLY PRESSURE TO THE OUTER-EDGE OF THE BEARING TO PREVENT DAMAGE TO THE INTERNAL COMPONENTS. DO NOT PUSH ON THE INNER, ROTATING RACE OF THE BEARING DURING INSTALLATION.

THE RADIAL BEARING IS DESIGNED TO FLOAT VERTICALLY IN THE BEARING BLOCKS, WHICH ALLOWS ALL AXIAL FORCES TO BE TRANSFERRED TO THE THRUST BEARINGS.

APPLY A SMALL AMOUNT OF MEDIUM-STRENGTH LOCTITE (BLUE 242 OR EQUIVALENT) TO THE OUTER SURFACE OF THE RADIAL BEARING TO HOLD IT IN PLACE DURING INSTALLATION. THIS WILL PREVENT THE BEARINGS FROM FALLING OUT DURING INSTALLATION/REMOVAL OF THE MAIN DRIVE GEAR ASSEMBLY, WHILE STILL ALLOWING THE RADIAL BEARING TO FLOAT AXIALLY UNDER HIGH LOADS OF FLIGHT. **DO NOT** USE BEARING RETAINER OR HIGH-STRENGTH LOCTITE FOR THE INSTALL.

APPLY ANY BEARING-QUALITY, SYNTHETIC OR SILICON-BASED GREASE TO THE THRUST BEARING COMPONENTS BEFORE INSTALLATION.

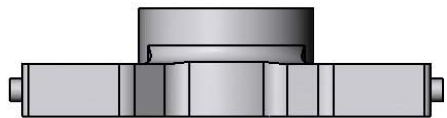

LOWER METAL BEARING BLOCK

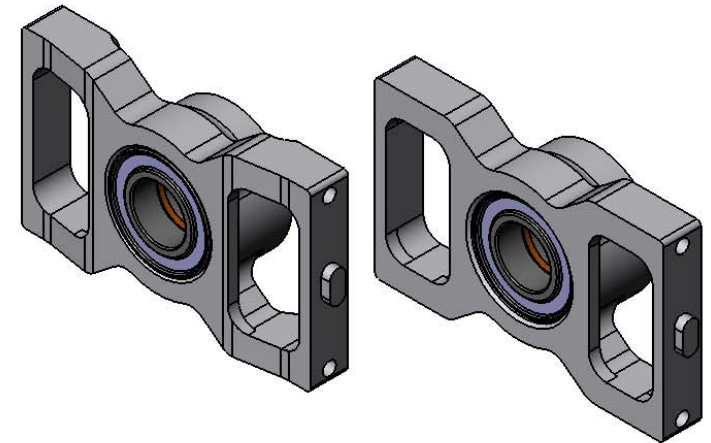
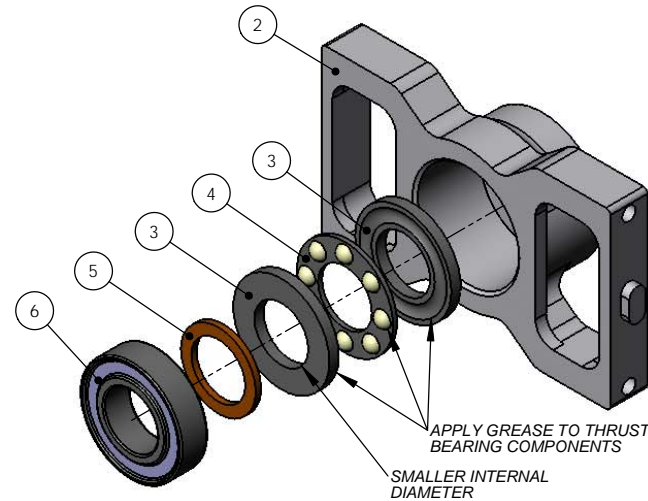

www.KDEDirect.com
AT600N-MBB