

**TREX700 SERIES MAIN DRIVE GEAR, 115T, MOD 1.0**  
**AT700-MDGM1 (NYLATRON GSM MoS2-FILLED TYPE 6 POLYAMIDE)**

ITEM NO.	DESCRIPTION	QTY.
1	TREX 700 SERIES MAIN DRIVE GEAR 115T, MOD 1.0	1
2	13T, MOD 1.0 PINION HARDENED STEEL (SHOWN FOR REFERENCE, SOLD SEPARATELY)	1
3	KDE DIRECT 1917H/1Y-N42 S2 HP BRUSHLESS MOTOR, 520kV (SHOW FOR REFERENCE, SOLD SEPARATELY)	1

**NOTE:** THE TREX 700 SERIES MAIN DRIVE GEAR HAS AN OPTIMIZED TOOTH INVOLUTE FOR INCREASED STRENGTH, DECREASED WEAR PROPERTIES, AND AN EXCEPTIONALLY QUIET GEAR MESH.

DUE TO THE OPTIMIZED TOOTH PROFILE, THE MOTOR PINION (HARDENED STEEL PREFERRED) CAN BE MESHED WITH THE MAIN DRIVE GEAR DEEPER THAN NORMAL FOR EXCEPTIONAL STRENGTH. WHEN SETTING THE GEAR MESH, ALLOW FOR A VERY MINUTE AMOUNT OF BACKLASH BETWEEN THE PINION AND MAIN DRIVE GEAR FOR OPTIMAL PLACEMENT. DURING THE INITIAL FLIGHT, THE PINION WILL MICROSCOPICALLY WEAR INTO THE GEAR AND SEAT ITSELF INTO THE OPTIMUM MESH FOR A STRONG, LONG-LASTING GEAR TRANSMISSION.

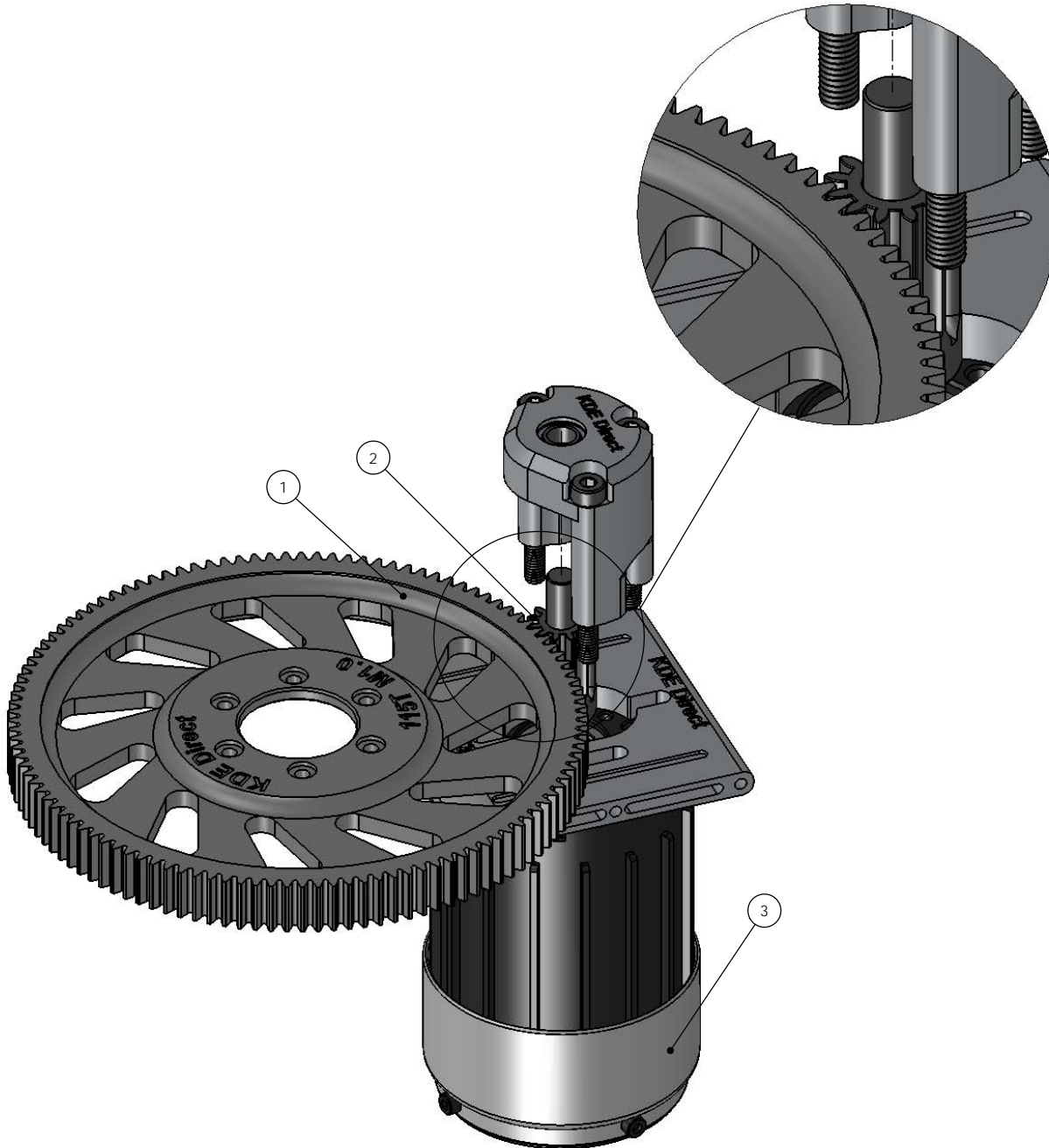

www.KDEDirect.com

www.KDEDirect.com  
**AT700-MDGM1**