

TREX700 TRIPLE BEARING BLOCK ASSEMBLY

AT700-TBB (AL 6061-T6, SS 416)

STEP 1

DRILL CARBON FRAMES FOR TRIPLE BEARING BLOCK (TREX 700E AND 700N E-CONVERSION VERSIONS)

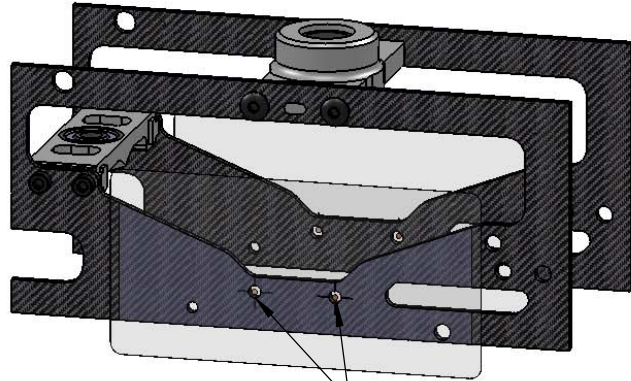

ATTACH ADHESIVE DRILLING TEMPLATE TO CARBON FRAMES (RIGHT AND LEFT SIDE INCLUDED) AND DRILL AT DUAL CROSSHAIR LOCATIONS TO 3.5MM (OR 1/8" IF NEEDED). REPEAT BOTH SIDES.

STEP 2

ASSEMBLE TRIPLE BEARING BLOCK UPGRADE

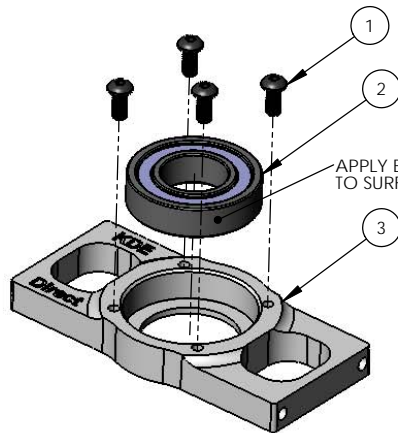

APPLY BEARING RETAINER (GREEN) TO SURFACE DURING INSTALLATION

STEP 3

INSTALL TRIPLE BEARING BLOCK COMPONENTS

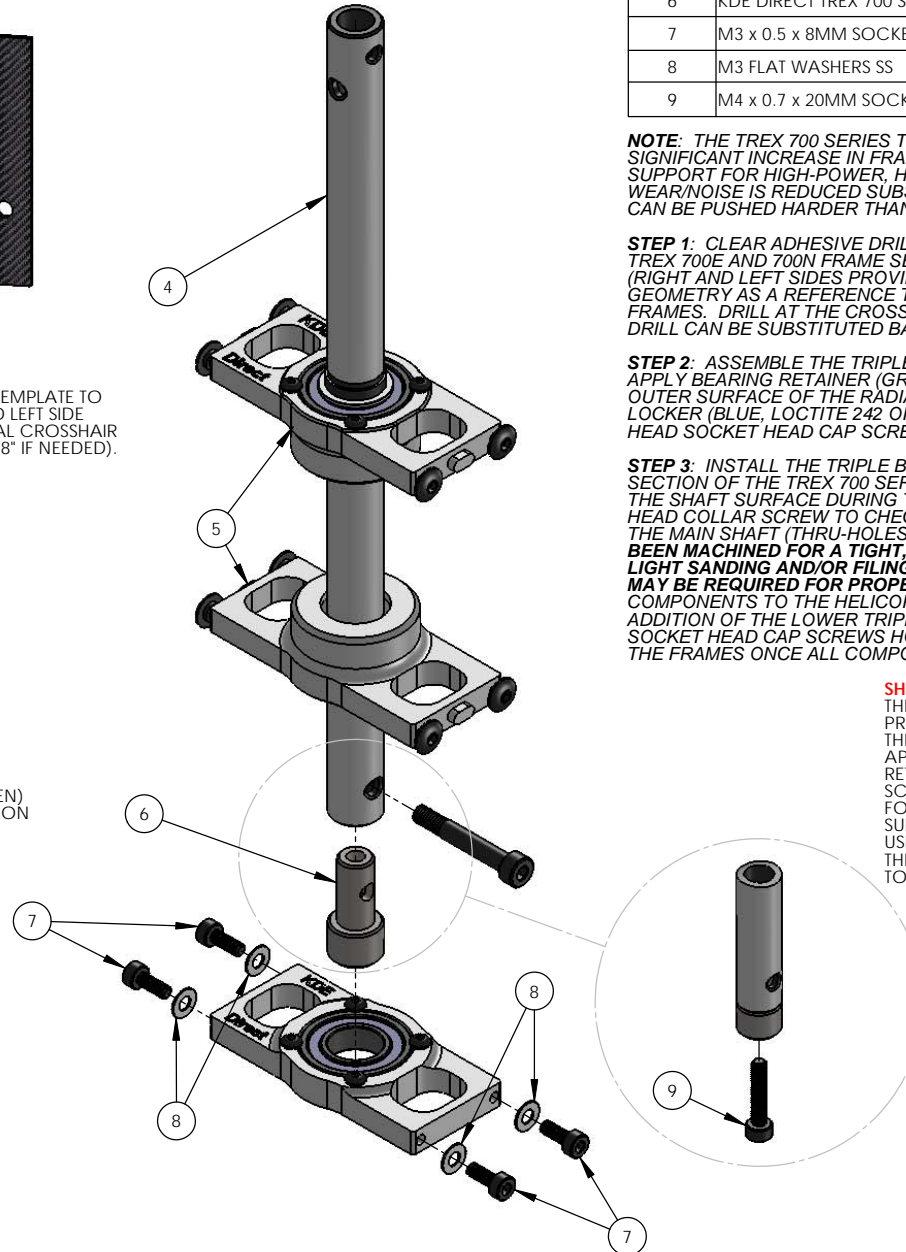

ITEM NO.	DESCRIPTION	QTY.
1	M2.5 x 0.45 x 6MM BUTTON HEAD SOCKET HEAD CAP SCREWS	4
2	RADIAL BALL BEARING 6901ZZ	1
3	KDE DIRECT TREX 700 SERIES TRIPLE BEARING BLOCK UPGRADE	1
4	TREX 700 SERIES MAIN SHAFT (PROVIDED IN ORIGINAL KIT)	1
5	KDE DIRECT TREX 700E SERIES THRUSTED METAL BEARING BLOCKS V2 (AT700E-MBB-V2, SOLD SEPARATELY) (THE STOCK ALIGN BEARING BLOCKS CAN ALSO BE USED)	2
6	KDE DIRECT TREX 700 SERIES TRIPLE BEARING SHAFT EXTENSION	1
7	M3 x 0.5 x 8MM SOCKET HEAD CAP SCREWS	4
8	M3 FLAT WASHERS SS	4
9	M4 x 0.7 x 20MM SOCKET HEAD CAP SCREW	1

NOTE: THE TREX 700 SERIES TRIPLE BEARING BLOCK UPGRADE PROVIDES A SIGNIFICANT INCREASE IN FRAME STIFFNESS AND GEAR/PINION INTERFACE SUPPORT FOR HIGH-POWER, HIGH-INTENSITY FLIGHTS. AS A RESULT, GEAR WEAR/NOISE IS REDUCED SUBSTANTIALLY AND THE 90-CLASS HELICOPTERS CAN BE PUSHED HARDER THAN EVER BEFORE.

STEP 1: CLEAR ADHESIVE DRILLING TEMPLATES ARE PROVIDED FOR BOTH THE TREX 700E AND 700N FRAME SETS. ATTACH THE ADHESIVE DRILLING TEMPLATE (RIGHT AND LEFT SIDES PROVIDED) TO THE CARBON FRAMES, USING THE GEOMETRY AS A REFERENCE TO PROPERLY ALIGN THE CROSSHAIRS TO THE FRAMES. DRILL AT THE CROSSHAIR CENTERPOINT LOCATIONS TO 3.5MM (AN 1/8" DRILL CAN BE SUBSTITUTED BASED ON AVAILABILITY) AND REPEAT BOTH SIDES.

STEP 2: ASSEMBLE THE TRIPLE BEARING BLOCK UPGRADE, MAKING SURE TO APPLY BEARING RETAINER (GREEN, LOCTITE 290 OR EQUIVALENT) TO THE OUTER SURFACE OF THE RADIAL BEARING AND MEDIUM-STRENGTH THREAD LOCKER (BLUE, LOCTITE 242 OR EQUIVALENT) TO THE SUPPLIED M2.5 BUTTON HEAD SOCKET HEAD CAP SCREWS DURING INSTALLATION.

STEP 3: INSTALL THE TRIPLE BEARING SHAFT EXTENSION INTO THE LOWER SECTION OF THE TREX 700 SERIES MAIN SHAFT. APPLY BEARING RETAINER TO THE SHAFT SURFACE DURING THE ASSEMBLY AND USE THE ALIGN M4 SOCKET HEAD COLLAR SCREW TO CHECK PROPER ALIGNMENT OF THE EXTENSION TO THE MAIN SHAFT (THRU-HOLES MUST LINE UP). THE SHAFT EXTENSION HAS BEEN MACHINED FOR A TIGHT, INTERFERENCE FIT TO THE STOCK MAIN SHAFT. LIGHT SANDING AND/OR FILING ON THE INSIDE SURFACE OF THE MAIN SHAFT MAY BE REQUIRED FOR PROPER FIT AND FULL INSERTION. ASSEMBLE ALL THE COMPONENTS TO THE HELICOPTER IN THE ORIGINAL ORDER, WITH THE ADDITION OF THE LOWER TRIPLE BEARING BLOCK. TIGHTEN THE M3 x 0.5 x 8MM SOCKET HEAD CAP SCREWS HOLDING THE TRIPLE BEARING BLOCK UPGRADE TO THE FRAMES ONCE ALL COMPONENTS ARE INSTALLED.

SHAFT EXTENSION REMOVAL AID:

THE M4 x 0.7 x 20MM SOCKET HEAD CAP SCREW IS PROVIDED TO AID IN DISASSEMBLY. IN THE EVENT THE SHAFT EXTENSION NEEDS TO BE REMOVED, APPLY HEAT TO THE JOINT TO SOFTEN THE BEARING RETAINER. THEN, THREAD THE M4 SOCKET HEAD CAP SCREW INTO THE SHAFT EXTENSION BORE (TAPPED FOR THIS PURPOSE), WHICH WILL PROVIDE A SURFACE TO CLAMP STRONGLY WITH A WRENCH. USE THIS SCREW TO PULL THE SHAFT EXTENSION FROM THE MAIN SHAFT EASILY, WITHOUT RISKING DAMAGE TO THE SHAFT EXTENSION BEARING SURFACE.

www.KDEDirect.com



www.KDEDirect.com
AT700-TBB