

# TREX700N E-CONVERSION ELECTRONIC PINION SUPPORT AT700N-EPS (AL 6061-T6, SS 416)

## GROUP A (MOTOR SHAFT LESS THAN 37mm)

### STEP 1 MOTOR SHAFT PREPARATION

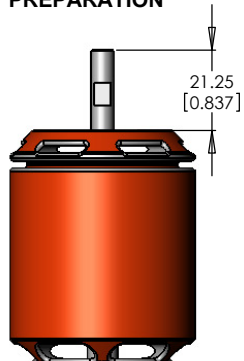

### STEP 2 PINION INSTALLATION

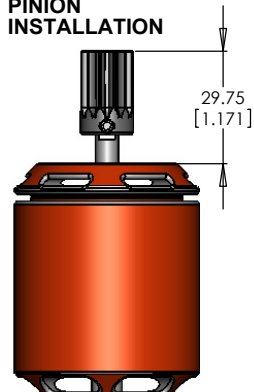

### STEP 3

#### M4 THREADED MOTOR INSTALLATION

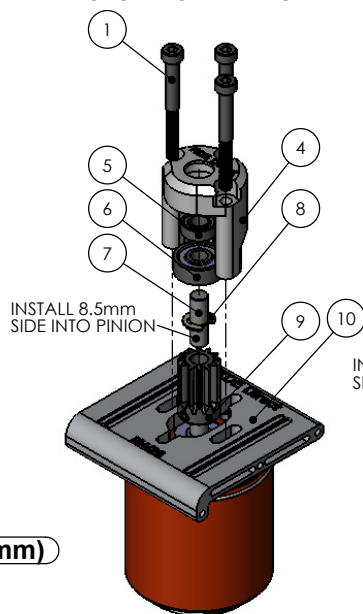

#### M3 THREADED MOTOR INSTALLATION

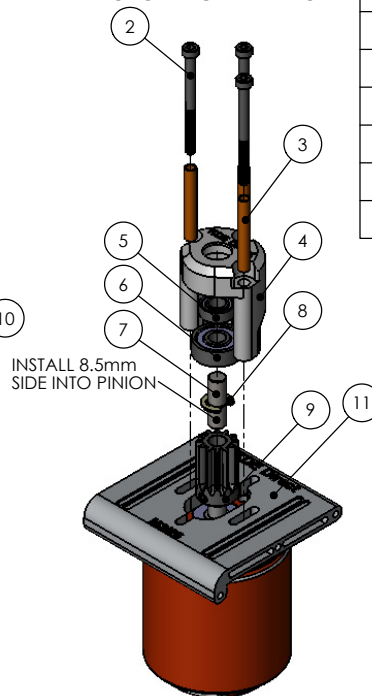

## GROUP B (MOTOR SHAFT MORE THAN 37mm)

### KDE 1917H-N42 HP BRUSHLESS MOTOR

#### STEP 1 PINION INSTALLATION

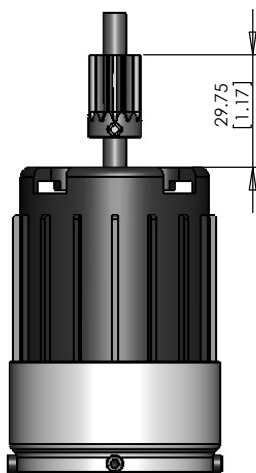

#### STEP 2 M4 THREADED MOTOR INSTALLATION

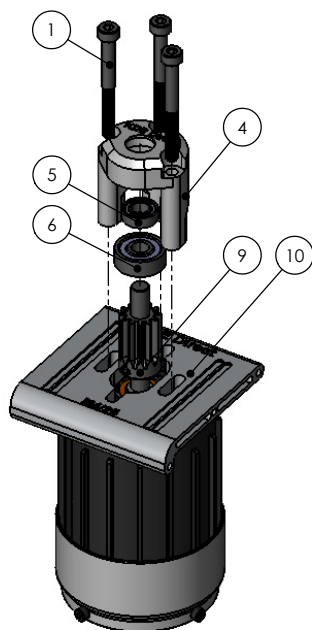

ITEM NO.	DESCRIPTION	QTY.
1	M4 x 0.7 x 40MM SOCKET HEAD CAP SCREW ALLOY STEEL	3
2	M3 x 0.5 x 40MM SOCKET HEAD CAP SCREW ALLOY STEEL	3
3	T700N ELECTRONIC PINION SUPPORT UPGRADE BRASS M3 ADAPTER	3
4	T700N ELECTRONIC PINION SUPPORT UPGRADE HOUSING 25MM OR 30MM VERSION	1
5	RADIAL BALL BEARING MR126ZZ	1
6	RADIAL BALL BEARING 606ZZ	1
7	T700N ELECTRONIC PINION SUPPORT SHAFT COMPONENT	1
8	E-STYLE RETAINING RING 6MM	1
9	MOTOR PINION (NOT INCLUDED, 13T MOD 1.0 SHOWN AS REFERENCE)	1
10	T700N ELECTRONIC CONVERSION KIT MOTOR MOUNT UPGRADE M4/25 OR M4/30 VERSION (SUPPLIED WITH AT700N-XECK/ECK)	1
11	T700N ELECTRONIC CONVERSION KIT MOTOR MOUNT UPGRADE M3/25 VERSION (SUPPLIED WITH AT700N-XECK/ECK)	1

**NOTE:** THE T700N ELECTRONIC PINION SUPPORT UPGRADE HAS BEEN MACHINED TO PRECISE TOLERANCES TO PROVIDE THE BEST SUPPORT POSSIBLE TO THE PINION AND MOTOR SHAFT FOR HIGH-POWER, HIGH-INTENSITY FLIGHTS.

**TO PROPERLY INSTALL THE PINION SUPPORT, THE MOTOR SHAFT MUST EXTEND A MINIMUM OF 37mm ABOVE THE TOP OF THE MOTOR CAN (SEE GROUP B). IF THE SHAFT IS LESS THAN THIS REQUIREMENT, THEN THE INCLUDED PINION SUPPORT SHAFT COMPONENT MUST BE INSTALLED (SEE GROUP A). PLEASE USE THE FOLLOWING STEPS FOR PROPER INSTALLATION:**

**STEP 1:** USING A DREMEL CUT-OFF WHEEL OR GRINDER, CUT THE SHAFT TO 21.25mm ABOVE THE TOP OF THE MOTOR CAN.

**STEP 2:** INSTALL THE MOTOR PINION TO 29.75mm ABOVE THE TOP OF THE MOTOR CAN.

**STEP 3:** DETERMINE THE CORRECT SIZE THREADS (M3 or M4) USED FOR MOUNTING THE MOTOR AND REFERENCE THE APPROPRIATE FIGURE SHOWN TO THE LEFT FOR ORDER OF INSTALLATION (SEE GROUP A).

**DO NOT PUSH ON THE INNER, ROTATING RACE OF THE BEARINGS DURING INSTALLATION. APPLY PRESSURE TO THE OUTER RING OF THE BEARING WHEN INSTALLING TO PREVENT PREMATURE DAMAGE TO THE INTERNALS OF THE BEARING.**

**IMPORTANT:** APPLY BEARING RETAINER AND/OR LOCTITE (RED 262, GREEN 290, OR STRONGER SERIES) TO THE PINION SUPPORT SHAFT COMPONENT TO PREVENT THE SHAFT FROM LOOSENING AND/OR SPINNING INSIDE THE PINION BORE. THIS WILL ENSURE PROPER OPERATION DURING USAGE IN FLIGHT. THE SHAFT HAS BEEN PRECISION GROUND TO 6.0mm AND MAY REQUIRE ADEQUATE PRESSURE TO INSTALL INTO THE INCLUDE BEARINGS.

www.KDEDirect.com



www.KDEDirect.com  
AT700N-EPS