

# TREX700N TAIL BOOM BRACE VIBRATION MANAGEMENT SYSTEM AT700N-TBBVMS (AL 6061-T6, SS 17-4PH)

## REAR FRAME COMPONENTS

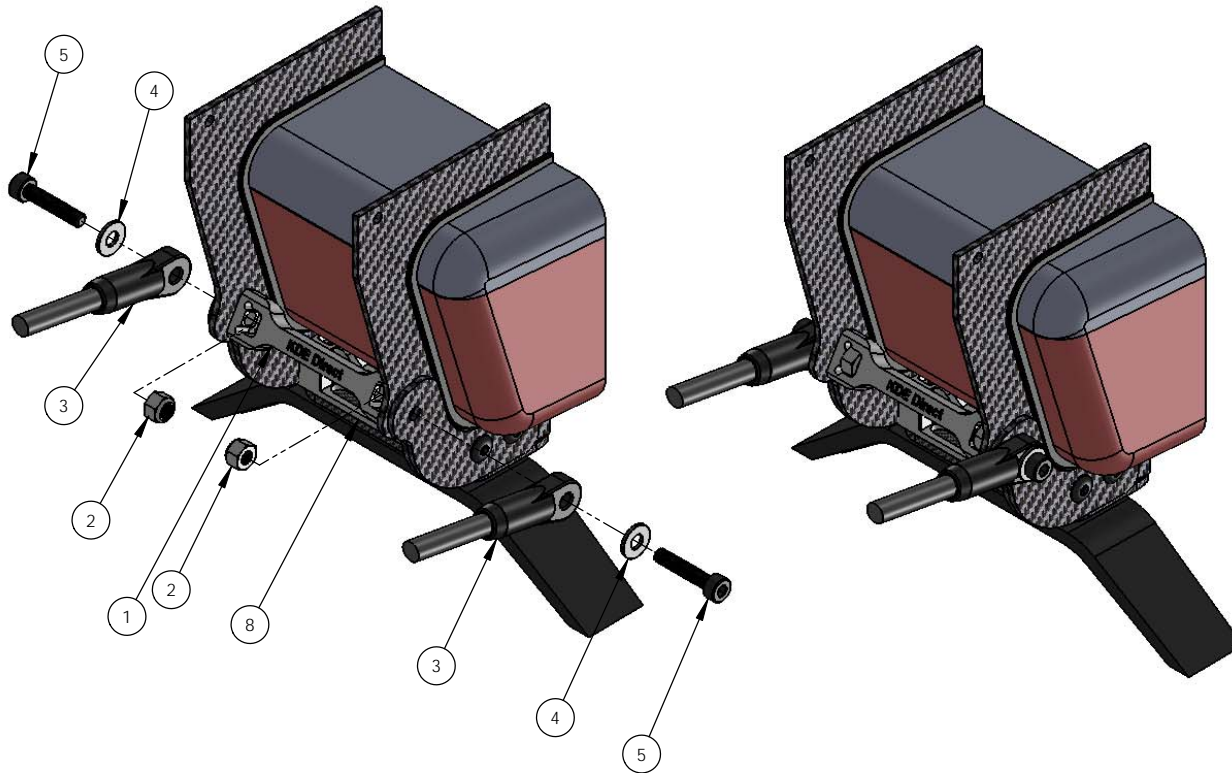

ITEM NO.	DESCRIPTION	QTY.
1	KDE DIRECT TREX 700N SERIES REAR FRAME MOUNTING BLOCK	1
2	M4 x 0.7 NYLON LOCKNUT ZP STEEL	4
3	TREX 700 SERIES TAIL BOOM BRACE (PROVIDED IN ORIGINAL KIT)	2
4	M4 WASHER (PROVIDED IN ORIGINAL KIT)	4
5	M4 x 0.7 x 20MM SOCKET HEAD CAP SCREW	2
6	TREX 700 SERIES LOWER STABILIZER MOUNT (PROVIDED IN ORIGINAL KIT)	1
7	KDE DIRECT TREX 700 SERIES LOWER STABILIZER MOUNT ADAPTER	2
8	KDE DIRECT TREX 700N SERIES FRAME MOUNT VMS (SOLD SEPARATELY)	2

**NOTE:** THE TREX 700 NITRO SERIES TAIL BOOM BRACE VIBRATION MANAGEMENT SYSTEM IS THE IDEAL SOLUTION FOR PREVENTING UNWANTED LOOSENING AND FAILURE OF THE TAIL BOOM BRACES CAUSED BY THE HIGH-VIBRATION NATURE OF THE NITRO HELICOPTER.

THE SYSTEM INCLUDES COMPONENTS FOR THE REAR FRAME AND REAR TAIL BOOM CONNECTION LOCATIONS OF THE TAIL BOOM BRACES.

**REAR FRAME COMPONENTS:** THE REAR FRAME MOUNTING BLOCK INCLUDES POCKETS TO CAPTURE THE INCLUDED M4 LOCKNUTS. THIS AIDS GREATLY IN INSTALLATION (NO NUT WRENCHES REQUIRED FOR TIGHTENING) AND LOCTITE IS NOT REQUIRED IN THIS AREA.

**REAR TAIL BOOM COMPONENTS:** BEFORE INSTALLING THE LOWER STABILIZER MOUNT ADAPTERS, APPLY RED LOCTITE (263 OR 271 PREFERRED) TO THE THREADS SHOWN IN THE DIAGRAM. ONCE LOCTITE HAS BEEN APPLIED, FIRMLY TIGHTEN THE ADAPTERS TO THE LOWER STABILIZER MOUNT USING AN 8MM (5/16") WRENCH OR HEX SOCKET TO FIRMLY BOND THE COMPONENTS. **PLEASE NOTE:** THE THREADS HAVE BEEN MACHINED TO INCLUDE A THREAD-LOCK GEOMETRY TOWARDS THE LAST FEW TURNS, THEREBY PRODUCING A MECHANICAL LOCK BETWEEN COMPONENTS TO FURTHER ENHANCE THE HOLDING STRENGTH AND RESISTANCE TO VIBRATION. RESISTANCE WILL BE FELT WHILE THREADING THE ADAPTERS INTO THE LOCKING SECTION, BUT CONTINUE TO TIGHTEN UNTIL THE INNER SURFACE OF THE HEX ADAPTER IS FLUSH WITH THE SIDEWALL OF THE LOWER STABILIZER MOUNT. **ALLOW TO CURE A MINIMUM OF 1 HOUR BEFORE FLIGHT.**

## REAR TAIL BOOM COMPONENTS

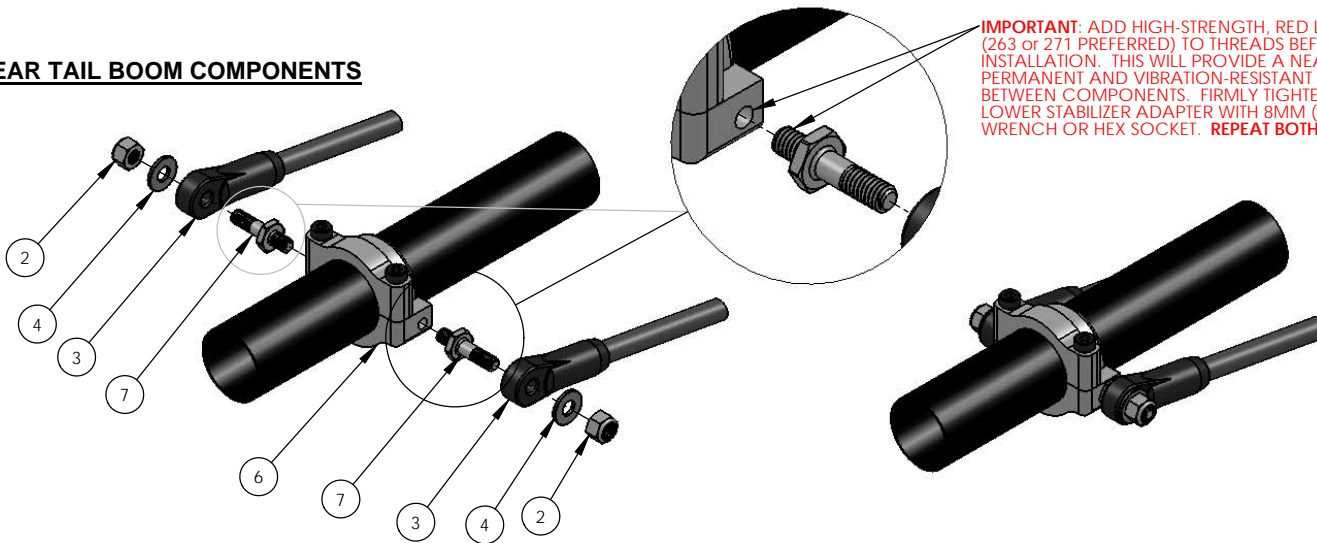

**IMPORTANT:** ADD HIGH-STRENGTH, RED LOCTITE (263 or 271 PREFERRED) TO THREADS BEFORE INSTALLATION. THIS WILL PROVIDE A NEAR-PERMANENT AND VIBRATION-RESISTANT BOND BETWEEN COMPONENTS. FIRMLY TIGHTEN LOWER STABILIZER ADAPTER WITH 8MM (5/16") WRENCH OR HEX SOCKET. **REPEAT BOTH SIDES.**

www.KDEDirect.com



www.KDEDirect.com  
AT700N-TBBVMS