

KDE DIRECT PERFORMANCE TAIL CONTROL FOR MIKADO™ LOGO® SERIES ML400/500/600-PTC (AL 6061-T6)

STEP 1

DISASSEMBLE TAIL PITCH ASSEMBLIES (SEE NOTES FOR INFORMATION)

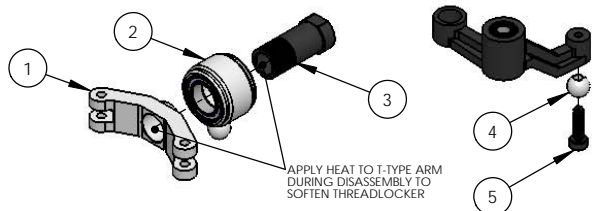

STEP 3: ASSEMBLY B

ASSEMBLE DESIGN ADAPTER TO CARBON TAIL CASE

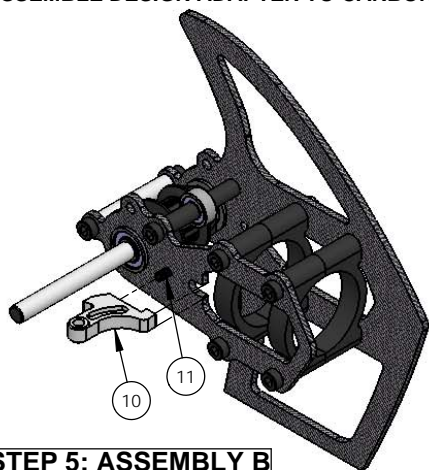

STEP 5: ASSEMBLY B

ASSEMBLE PRIMARY LINK MECHANICS

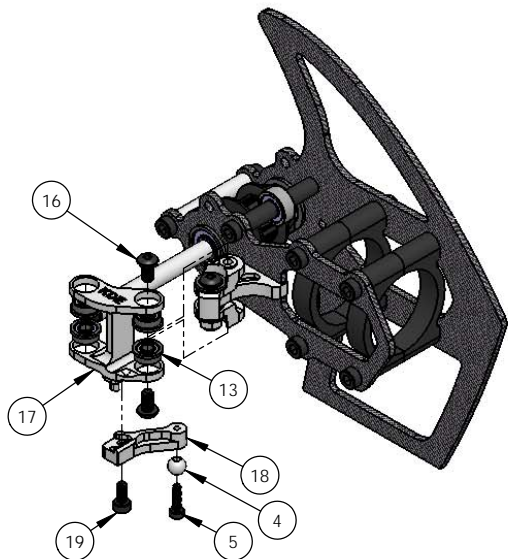

STEP 2: ASSEMBLY A

ASSEMBLE PERFORMANCE TAIL PITCH ASSEMBLY

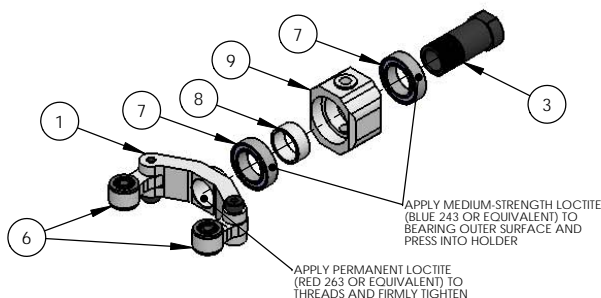

STEP 4: ASSEMBLY B

ASSEMBLE SECONDARY LINK MECHANICS

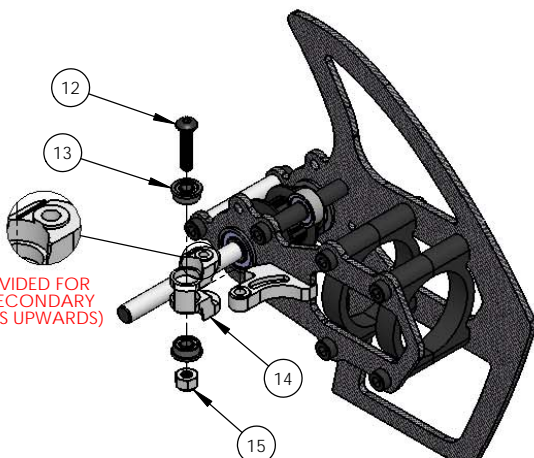

NOTE: NOTCH PROVIDED FOR ORIENTATION OF SECONDARY LINK (NOTCH FACES UPWARDS)

STEP 6

ASSEMBLE INTO LOGO® 400/500/600SE SERIES TAIL SYSTEM

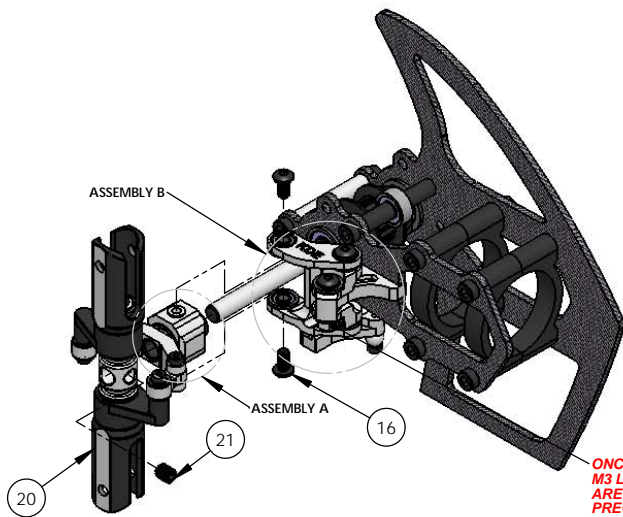

ONCE FULLY-TIGHTENED, PRESSURE TO THE SYSTEM CAN BE ADJUSTED WITH THE M3 LOCKNUT INSTALLED IN STEP 4. TIGHTEN OR LOOSEN UNTIL THE MECHANICS ARE SMOOTH AND SLOP-FREE TO YOUR PREFERENCE AND ENJOY THE NEW PRECISION-CONTROL TAIL SYSTEM.

ITEM NO.	DESCRIPTION	QTY.
1	ALIGN TREX 550/600 SERIES T-TYPE ARM (REQUIRES PURCHASE OF ALIGN PART #H60077A)	1
2	ALIGN TREX 550/600 SERIES BEARING HOLDER ASSEMBLY (REQUIRES PURCHASE OF ALIGN PART #H60077A)	1
3	ALIGN TREX 550/600 SERIES SLIDE SHAFT (REQUIRES PURCHASE OF ALIGN PART #H60077A)	1
4	MIKADO™ LOGO® SERIES LINKAGE BALL (INCLUDED IN ORIGINAL KIT)	1
5	M2 x 0.4 x 8MM SOCKET HEAD CAP SCREW (INCLUDED IN ORIGINAL KIT)	1
6	KDE DIRECT TREX 550/600/700 SERIES PERFORMANCE TAIL UPGRADE V2 (SEE INSTALLATION DIAGRAM FOR REFERENCE)	2
7	MR117ZZ RADIAL BALL BEARING	2
8	KDE DIRECT TREX 550/600 SERIES PERFORMANCE TAIL CONTROL BEARING COLLAR	1
9	KDE DIRECT TREX 550/600 SERIES PERFORMANCE TAIL CONTROL BEARING HOLDER	1
10	KDE DIRECT TREX 550/600 SERIES PERFORMANCE TAIL CONTROL DESIGN ADAPTER	1
11	M2.5 x 0.45 x 8MM SOCKET HEAD CAP SCREW (INCLUDED IN ORIGINAL KIT)	1
12	M3 x 0.5 x 14MM BUTTON HEAD SOCKET HEAD CAP SCREW	1
13	F683ZZ FLANGED RADIAL BALL BEARING	6
14	KDE DIRECT TREX 550/600 SERIES PERFORMANCE TAIL CONTROL SECONDARY LINK	1
15	M3 x 0.5 NYLON INSERT HEX LOCKNUT ALLOY STEEL	1
16	M3 x 0.5 x 6MM BUTTON HEAD SOCKET HEAD CAP SCREW	4
17	KDE DIRECT TREX 550/600 SERIES PERFORMANCE TAIL CONTROL PRIMARY LINK	1
18	KDE DIRECT TREX 550/600 SERIES PERFORMANCE TAIL CONTROL ARM LEVER	1
19	M2.5 x 0.45 x 6MM SOCKET HEAD CAP SCREW	1
20	ALIGN TREX 550/600/700 SERIES TAIL ROTOR HOLDER ASSEMBLY (REQUIRES PURCHASE OF ALIGN PART #H60109, HN6103, OR HN6103A)	1
21	M4 x 0.7 x 4MM SOCKET HEAD CAP SCREW CUP POINT (INCLUDED IN ALIGN TAIL ROTOR HOLDER ASSEMBLY, ITEM #20)	1

NOTE: THE PERFORMANCE TAIL CONTROL UPGRADE PROVIDES THE ULTIMATE, SLOP-FREE CONTROL SYSTEM AVAILABLE ON THE MARKET TO YIELD PRECISE TAIL CONTROL AND AUTHORITY. WITH THE INCLUDED DESIGN ADAPTER UNIT (ML400/500/600-PTCDA, ALSO SOLD SEPARATELY), THE UPGRADE CAN BE ADAPTED TO MIKADO™ LOGO® 400/500/600SE SERIES HELICOPTER AND OTHER BRAND MODELS FOR HIGH-PERFORMANCE FLIGHT CAPABILITY. FOR PROPER INSTALLATION, ADDITIONAL ALIGN-BRAND COMPONENTS ARE REQUIRED (PURCHASED SEPARATELY):

H60077A, ALIGN TREX 550/600 SERIES METAL TAIL PITCH ASSEMBLY
HN6103*, ALIGN TREX 550/600/700 SERIES METAL TAIL ROTOR HOLDER ASSEMBLY
*OPTION TO USE ALTERNATE ASSEMBLIES: H60109 OR HN6103A

DUE TO THE PRECISION CNC-MACHINING OF EACH COMPONENT, CORRECT INSTALLATION IS KEY FOR PROPER, BIND-FREE OPERATION. PLEASE PAY ATTENTION TO THE INSTRUCTIONS AND TAKE YOUR TIME WHEN INSTALLING THE ASSEMBLY. MAKE SURE TO APPLY MEDIUM-STRENGTH LOCTITE (BLUE 243 OR EQUIVALENT) TO ALL SCREWS AND OUTER SURFACE OF RADIAL BALL BEARINGS DURING ASSEMBLY. IN ADDITION, LEAVE ALL SCREWS LOOSELY INSTALLED UNTIL STEP 6.

STEP 1: DISASSEMBLE THE ALIGN TAIL PITCH ASSEMBLY TO REMOVE THE STOCK BEARING HOLDER AND CONTROL ARM. USING A HEAT-GUN, FLAME, OR ALTERNATE HEAT-SOURCE, APPLY HEAT TO THE THREADS HOLDING THE SLIDE SHAFT TO THE T-TYPE ARM. ONCE THE LOCTITE HAS SOFTENED AND RELEASED, UNSCREW THE SLIDE SHAFT FROM THE T-TYPE ARM AND SET ASIDE.

STEP 2: ASSEMBLE THE PERFORMANCE TAIL PITCH ASSEMBLY AS SHOWN IN THE DIAGRAM. TIGHTEN THE SLIDE SHAFT FIRMLY TO ACCURATELY SEAT THE RADIAL BALL BEARINGS INTO THE HOLDER AND PROVIDE A SLOP-FREE HOLD.

STEP 3: ASSEMBLE THE PERFORMANCE TAIL CONTROL DESIGN ADAPTER TO THE CARBON TAIL CASE USING THE STOCK MACHINED SLOT AND M2.5 SOCKET HEAD CAP SCREW AS A GUIDE FOR INSTALLATION.

STEP 4: ASSEMBLE THE PERFORMANCE TAIL CONTROL SECONDARY LINK AS SHOWN IN THE DIAGRAM. LOOSELY TIGHTEN THE M3 LOCKNUT UNTIL THREADS ARE ENGAGED, BUT LEAVE LOOSE UNTIL STEP 6.

STEP 5: ASSEMBLE THE PERFORMANCE TAIL CONTROL PRIMARY LINK AS SHOWN IN THE DIAGRAM. INSTALL THE M3 BUTTON HEAD SOCKET HEAD CAP SCREWS AND M2.5 SOCKET HEAD CAP SCREW AS SHOWN (LEAVE M3 SCREWS LOOSELY INSTALLED). BALL LINK AND M2 SOCKET HEAD CAP SCREW OBTAINED FROM THE STOCK LOGO® 400/500/600 SERIES TAIL CONTROL ARM ASSEMBLY (OBTAINED IN STEP 1).

STEP 6: INSTALL BOTH ASSEMBLIES AND CHECK FOR SMOOTH OPERATION OF ALL COMPONENTS. PROCEED TO TIGHTEN THE M3 BUTTON HEAD SOCKET HEAD CAP SCREWS TO COMPLETE INSTALLATION.

MIKADO AND LOGO ARE TRADEMARKS OF MIKADO MODEL HELICOPTERS, GMBH. PRODUCTS ADVERTISED ON THIS SITE AS COMPATIBLE FOR USE WITH MIKADO HELICOPTERS ARE NOT MADE, ENDORSED, OR APPROVED BY MIKADO.



www.KDEDirect.com
ML400/500/600-PTC